

CE DECLARATION OF CONFORMITY

Manufacturer : FAAC S.p.A.

Address: Via Benini, 1 - 40069 Zola Predosa BOLOGNA - ITALY

Declares that: 578D control board,

- conforms to the essential safety requirements of the following directives:
73/23/EEC and subsequent amendment 93/68/EEC.
89/336/EEC and subsequent amendment 92/31/EEC and 93/68/EEC

Additional note:

This product underwent tests in a typical uniform configuration
(all products manufactured by FAAC S.p.A.).

Bologna, 01 January 2004

The Managing Director
A. Bossi



WARNINGS FOR THE INSTALLER

GENERAL SAFETY OBLIGATIONS

- ATTENTION! To ensure the safety of people, it is important that you read all the following instructions. Incorrect installation or incorrect use of the product could cause serious harm to people.**
- Carefully read the instructions before beginning to install the product.
- Do not leave packing materials (plastic, polystyrene, etc.) within reach of children as such materials are potential sources of danger.
- Store these instructions for future reference.
- This product was designed and built strictly for the use indicated in this documentation. Any other use, not expressly indicated here, could compromise the good condition/operation of the product and/or be a source of danger.
- FAAC declines all liability caused by improper use or use other than that for which the automated system was intended.
- Do not install the equipment in an explosive atmosphere: the presence of inflammable gas or fumes is a serious danger to safety.
- The mechanical parts must conform to the provisions of Standards EN 12604 and EN 12605.
For non-EU countries, to obtain an adequate level of safety, the Standards mentioned above must be observed, in addition to national legal regulations.
- FAAC is not responsible for failure to observe Good Technique in the construction of the closing elements to be motorised, or for any deformation that may occur during use.
- The installation must conform to Standards EN 12453 and EN 12445.
For non-EU countries, to obtain an adequate level of safety, the Standards mentioned above must be observed, in addition to national legal regulations.
- Before attempting any job on the system, cut out electrical power.
- The mains power supply of the automated system must be fitted with an all-pole switch with contact opening distance of 3mm or greater. Use of a 6A thermal breaker with all-pole circuit break is recommended.
- Make sure that a differential switch with threshold of 0.03 A is fitted upstream of the system.
- Make sure that the earthing system is perfectly constructed, and connect metal parts of the means of the closure to it.
- The safety devices (EN 12978 standard) protect any danger areas against **mechanical movement Risks**, such as crushing, dragging, and shearing.
- Use of at least one indicator-light (e.g. FAACLIGHT) is recommended for every system, as well as a warning sign adequately secured to the frame structure, in addition to the devices mentioned at point "15".
- FAAC declines all liability as concerns safety and efficient operation of the automated system, if system components not produced by FAAC are used.
- For maintenance, strictly use original parts by FAAC.
- Do not in any way modify the components of the automated system.
- The installer shall supply all information concerning manual operation of the system in case of an emergency, and shall hand over to the user the warnings handbook supplied with the product.
- Do not allow children or adults to stay near the product while it is operating.
- Keep remote controls or other pulse generators away from children, to prevent the automated system from being activated involuntarily.
- Transit is permitted only when the automated system is idle.
- The user must not attempt any kind of repair or direct action whatever and contact qualified personnel only.
- Maintenance: check at least every 6 months the efficiency of the system, particularly the efficiency of the safety devices (including, where foreseen, the operator thrust force) and of the release devices.
- Anything not expressly specified in these instructions is not permitted.**

CONTROL BOARD 578D

1. WARNINGS

Important: Before attempting any work on the control board (connections, maintenance), always turn off power.

- Install, upstream of the system, a differential thermal breaker with adequate tripping threshold.
- Connect the earth cable to the appropriate terminal on the J7 connector of the equipment (see fig.2).
- Always separate power cables from control and safety cables (push-button, receiver, photocells, etc.). To avoid any electric noise, use separate sheaths or a shielded cable (with earthed shield).

2. TECHNICAL SPECIFICATIONS

Power supply V~ (+6% -10%)	230
Absorbed power (W)	10
Motor max. load (W)	1000
Accessories max. load (A)	0,5
Operating ambient temperature	-20 °C +55 °C
Protection fuses	2 (see fig. 1)
Function logics:	Automatic / "Stepped" automatic / Semi-automatic / Safety devices / Semi-automatic B / Dead-man C / "Stepped" semi-automatic / Mixed B/C logic
Work time	Programmable (from 0 to 4 min.)
Pause time	Programmable (from 0 to 4 min.)
Thrust force	Adjustable over 50 levels
Terminal board inputs:	Open - Partial Open - Opening safety devices - Closing safety devices - Stop - Edge - Power supply+Earth - Opening and closing limit-switches - Encoder
Terminal board outputs:	Flashing lamp - Motor - 24 Vdc accessories power supply- 24 Vdc indicator-light / Timed output / Electric lock command - 'traffic lights' - Failsafe
Rapid connector	5-pin card connection for Minidec, Decoder or RP receivers
Programming	3 keys (+, -, F) and display, "basic" or "advanced" mode
Basic mode programmable functions:	Function logic - Pause time - Thrust Force - Opening-closing direction
Advanced mode programmable functions:	Torque at initial thrust - Braking - Fail safe- Pre-flashing - Indicator-light/Timed output/Electric lock or 'traffic lights' command -Opening and closing safety devices logic - Encoder/ Anti-crushing sensitivity -Decelerations - Partial opening time - Work time - Assistance request - Cycle counter

3. LAYOUT AND COMPONENTS

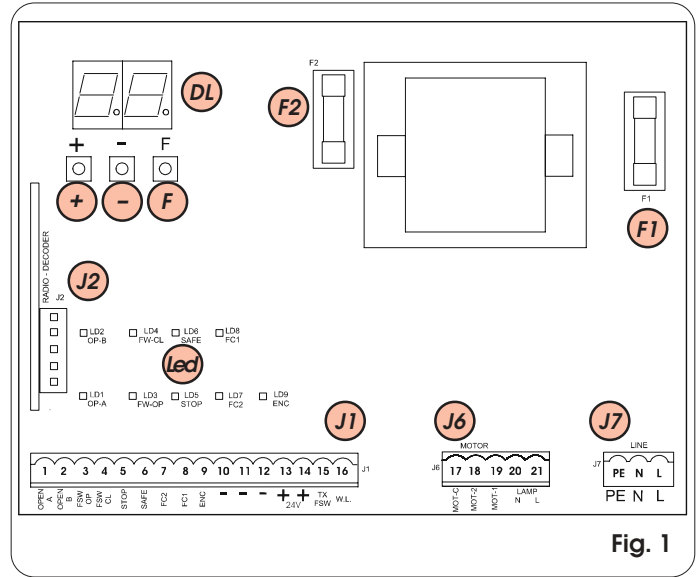
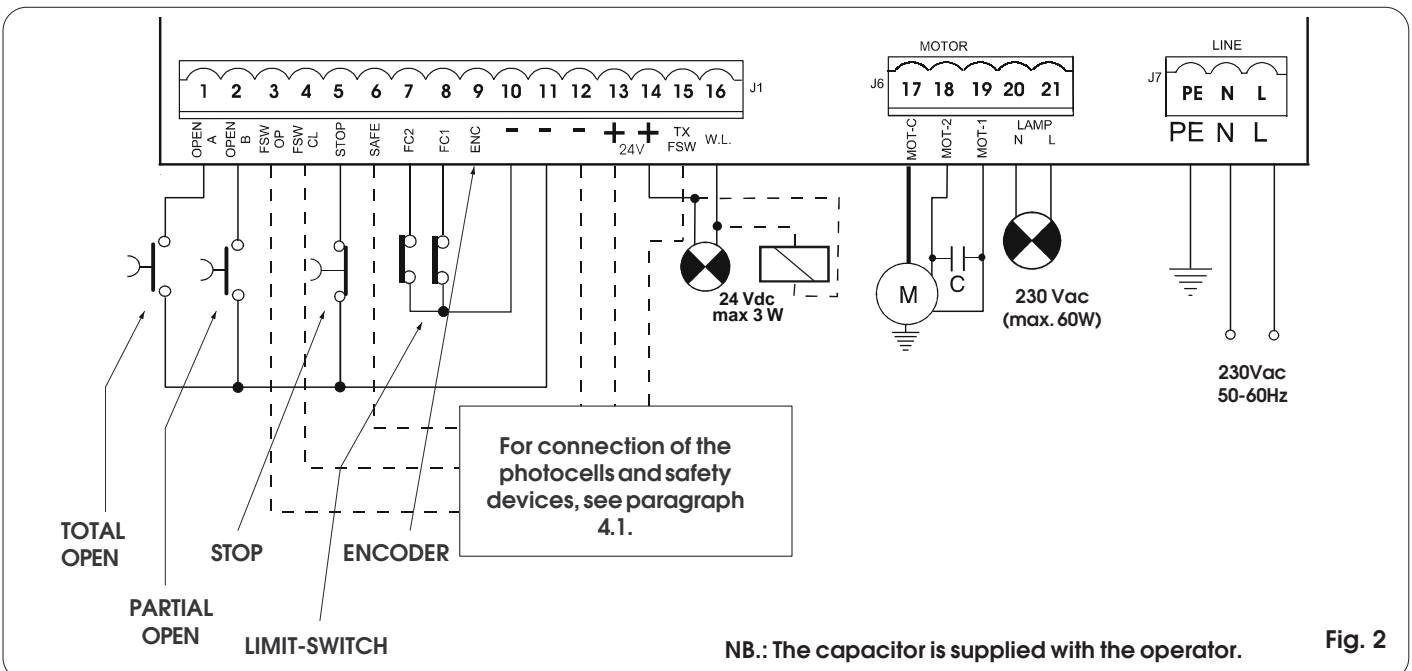

Fig. 1

DL	SIGNALLING AND PROGRAMMING DISPLAY
Led	INPUTS STATUS CONTROL LED
J1	LOW VOLTAGE TERMINAL BOARD
J2	CONNECTOR FOR DECODER/MINIDEC/RP RECEIVER
J6	MOTORS AND FLASHING LAMP CONNECTION TERMINAL BOARD
J7	230 Vac POWER SUPPLY TERMINAL BOARD
F1	MOTORS AND TRANSFORMER PRIMARY WINDING FUSE (F 5A)
F2	LOW VOLTAGE AND ACCESSORIES FUSE (T 800mA)
F	"F" PROGRAMMING PUSH-BUTTON
-	"-" PROGRAMMING PUSH-BUTTON
+	"+" PROGRAMMING PUSH-BUTTON

4. ELECTRIC CONNECTIONS



NB.: The capacitor is supplied with the operator.

Fig. 2

NOTE: The 578D equipment is able to command electro-mechanical operators for sliding gates and industrial sectional doors. Anything referring to gates in these instructions also applies to doors. Any differences are shown in the specific paragraphs.

4.1. Connection of photocells and safety devices

Before connecting the safety devices and photocells we advise you to select the type of operation according to the movement area they have to protect (see fig.3 for example):

Opening safety devices: they are tripped when an obstacle is detected only during gate opening movement. They cause immediate closure and resumption of opening motion on release (see programming in par.5.2).

Closing safety devices: they are tripped when an obstacle is detected only during gate closing movement. They cause re-opening, either immediate or on release (see programming in par.5.2).

Opening/closing safety devices: they are tripped during the gate opening and closing movements. They cause stopping and restart motion on release.

"Edge" safety devices: they are tripped during the gate opening and closing movements. They cause immediate reversal of motion and stopping after two seconds.

Encoder: it is tripped if there is an obstacle during gate opening and closing movements. It causes immediate reversal of motion and stopping after two seconds.

Note: in operators for industrial sectional doors, the anti-crushing function is not tripped during closing, because the operator acts on the rope shaft and not directly on the door.

N.B. If two or more safety devices have the same function (opening, closing, opening and closing, edge), the contacts must be connected to each other in series (fig. 4).

N.C. contacts must be used.

N.B: If safety devices are not used, jumper connect the terminals as shown in fig. 5.

The most common photocell and safety device lay-outs are shown below (from fig. 6 to fig. 13).

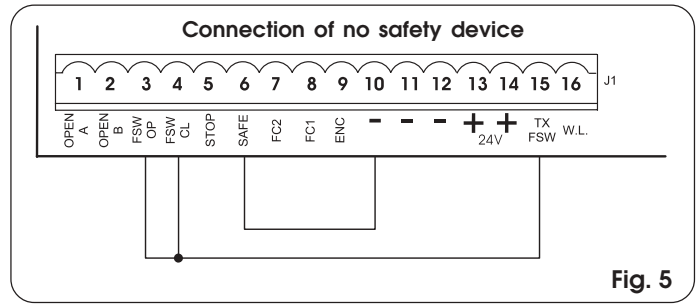

Fig. 5

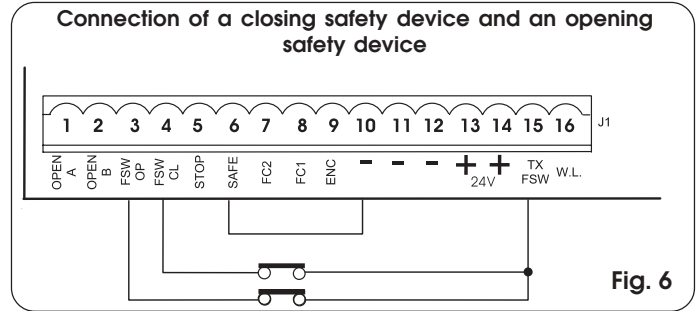

Fig. 6

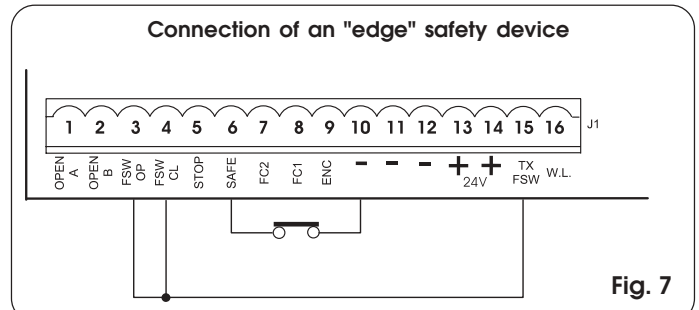

Fig. 7

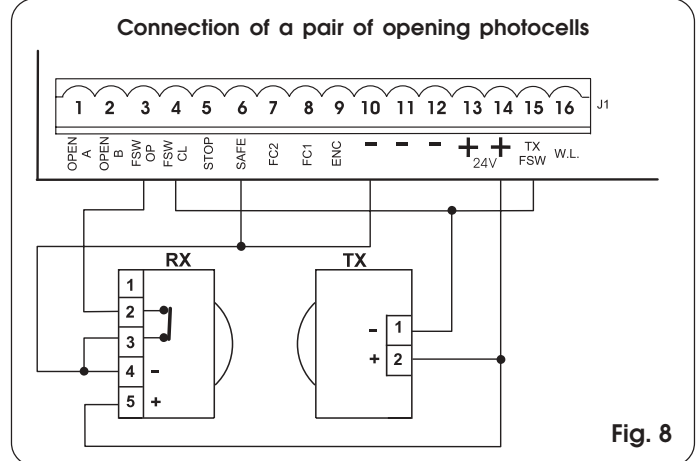

Fig. 8

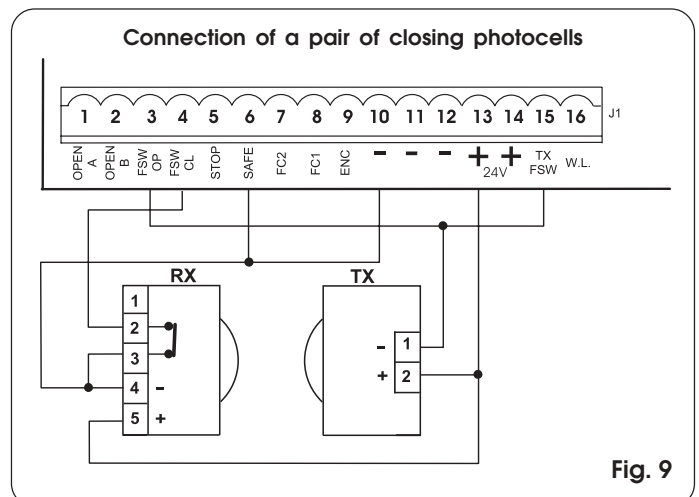

Fig. 9

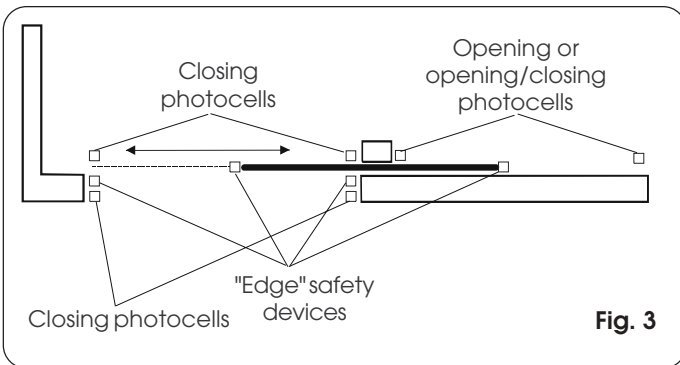

Fig. 3

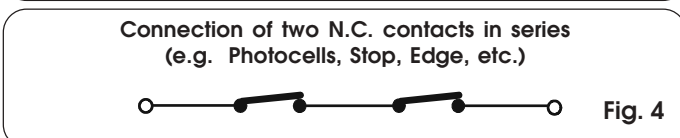
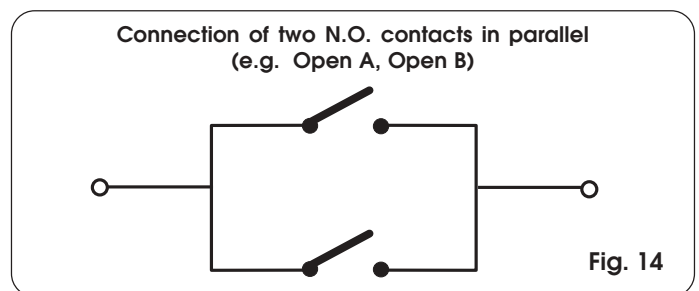
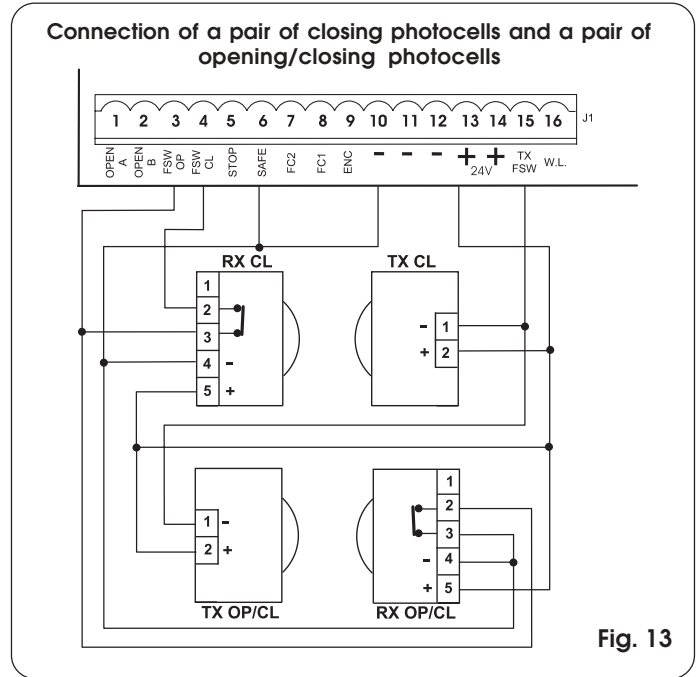
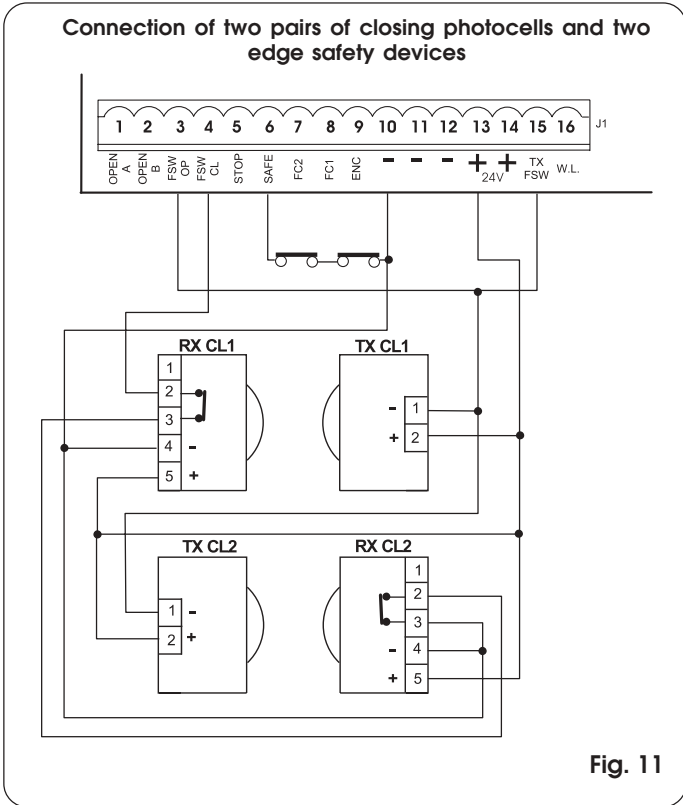
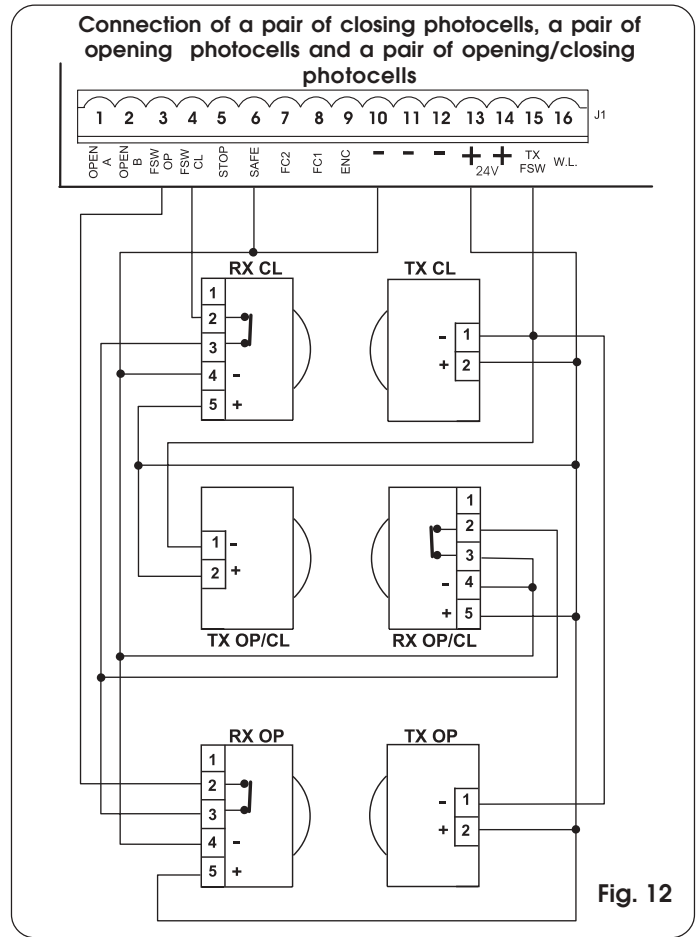
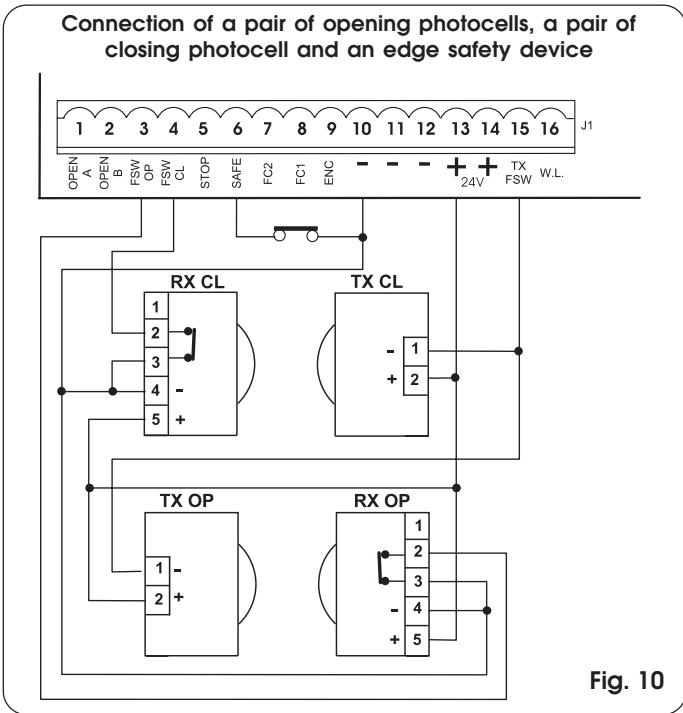

Fig. 4



4.2. Terminal board - Power supply (fig. 2)

POWER SUPPLY (terminals PE-N-L):

PE: Earth connection

N : Power supply (Neutral)

L : Power supply (Line)

NB.: For correct operation, the board must be connected to the earth conductor in the system. Install an adequate differential thermal breaker upstream of the system.

4.3. J6 Terminal board - Motors and flashing lamp (fig. 2)

MOTOR - (terminals 17-18-19): Motor connection.

Operators for sliding gates: refer to paragraph 4.6 for instructions on correct connection of the equipment to the interface board on the operator.

Operator 541: refer to paragraph 4.7 for instructions on correct connection of the equipment to the interface board on the operator.

LAMP - (terminals 20-21): Flashing lamp output 230Vac max 60W.

4.4. J1 Terminal board - Accessories (fig. 2)

Consult the relevant tables for a detailed description of operation in the different logics

OPEN A - "Total Opening" command (terminal 1): any pulse generator (push-button, detector, etc.) which, by closing a contact, commands total opening and/or closing of the gate leaf.

To install several total opening pulse generators, connect the N.O. contacts in parallel (fig. 14).

OPEN B - "Partial opening" or "Closing" command (terminal 2): any pulse generator (push-button, detector, etc.) which, by closing a contact, commands partial opening and/or closing of the gate leaf. In the B, C and B/C logics, it always commands gate closure.

To install several partial opening pulse generators, connect the N.O. contacts in parallel (fig. 14).

FSW OP - Opening safety devices contact (terminal 3): The purpose of the opening safety devices is to protect the leaf movement area during opening. During opening, in the **A-AP-S-E-EP** logics the safety devices reverse the movement of the gate, or stop and restart the movement when it is released (see advanced programming in Chpt. 5.2). During the opening cycle in logics the **B, C** and **B/C**, they interrupt movement. They never operate during the closing cycle.

If the **Opening safety devices** are engaged when the gate is closed, they prevent the opening movement. To install several safety devices, connect the N.C. contacts in series (fig. 4).

NB.: If no opening safety devices are connected, jumper connect inputs **FSW OP** and **-TX FSW** (fig. 5).

FSW CL - Closing safety devices contact (terminal 4): The purpose of the closing safety devices is to protect the gate movement area during closing. During closing, in the **A-AP-S-E-EP** logics, the safety devices reverse the movement of the gate, or stop and reverse the movement when it is released (see advanced programming in Chpt. 5.2). During the closing cycle in logics **B, C** and **B/C**, they interrupt movement. They never operate during the opening cycle. If the **Closing safety devices** are

engaged when the gate is open, they prevent the closing movement.

To install several safety devices, connect the N.C. contacts in series (fig. 4).

NB.: If no closing safety devices are connected, jumper connect terminals **FSW CL** and **-TX FSW** (fig. 5).

STOP - STOP contact (terminal 5): any device (e.g. a push-button) which, by opening a contact, stops gate movement.

To install several STOP devices, connect the N.C. contacts in series (fig. 4).

NB.: If STOP devices are not connected, jumper connect the **STOP** and - terminals.

SAFE - EDGE safety device contact (terminal 6): The purpose of the "edge" safety device is to protect the leaf movement area during opening/closing. In all logics, during opening and closing, the safety device reverses gate movement for 2 seconds. If the safety devices operate again during the 2-seconds reversing time, it stops movement (STOP) without any reversing.

If the **Edge safety device** is engaged while the gate is closed or open, it prevents movement.

To install several safety devices, connect the N.C. contacts in series (fig. 4).

NB.: If edge safety devices are not connected, jumper connect the **SAFE** and - inputs (fig. 5).

FC1 / FC2 - Opening and closing limit-switch contacts (terminals 7 and 8): The purpose of the opening and closing limit-switches is to establish the reference point for the stop, or for start of deceleration (pre- and post-limit-switch), or for operator braking (see advanced programming in Chpt 5.2). The limit-switch device must have an NC contact for connection between the input (FC1 or FC2) and the equipment's terminal (see Fig. 2).

OPERATORS FOR SLIDING GATES: consult paragraph 4.6 for correct connection of limit-switches and motor.

OPERATOR 541: consult paragraph 4.7 for correct connection of limit-switches and motor.

ENCODER - Contacts of motor rotation control sensor (terminal 9): This input is designed for connection of the Encoder sensor. The presence of the encoder is signalled - when the gearmotor is running - by the flashing of the "ENC" LED on the board. If the encoder is used, the equipment knows the exact gate position during the entire movement, and also controls other functions with greater precision, such as partial opening and decelerations (see advanced programming in Chpt 5.2). The encoder also operates as an anti-crushing device: if the gate strikes an obstacle during opening or closing, the encoder reverses gate leaf movement for 2 seconds. If the encoder operates again during the 2-second reversing time, it STOPS movement without performing any reversing. **Note: in operators for industrial sectional doors, the anti-crushing function is not active during closing, because the operator acts on the rope shaft and not directly on the door.**

- **Negative for power supply to accessories (terminals 10, 11 and 12)**

+ **24 Vdc - Positive for power supply to accessories (terminals 13 and 14)**

Important: Accessories max. load is 500 mA. To calculate absorption values, refer to the instructions for individual accessories.

TX -FSW - Negative for power supply to photocell transmitters (terminal 15)

If you use this terminal for connecting the negative for supplying power to the photocell transmitters, you may, if necessary, also use the FAIL SAFE function (see advanced programming in Chpt. 5.2).

If this function is enabled, the equipment checks

operation of the photocells before every opening or closing cycle.

W.L. - Powersupply to indicator light / timed exit / electric lock/ 'traffic lights' (terminal 16)

Connect any 24 Vdc - 3 W max indicator light, timed exit, command device for electric lock or 'traffic lights' between this terminal and the +24V (see advanced programming in Chap. 5.2). To avoid jeopardising correct operation of the system, **do not exceed** the indicated power.

4.5. Connector J2- Rapid connection to Minidec, Decoder and RP

This is used for rapid connection of Minidec, Decoder and RP receivers (see fig. 15, 16 and 17). Connect the accessory, with the components side facing the inside of the board. Insert and remove after cutting power.

4.6. Connection of operator 844

Make the connections between the 578D equipment and the inter-connection board mounted on the operator, observing the diagram in fig.18. Refer to paragraph 6.2 for instructions on putting into operation.

4.7. Connection of operator 541

Make the connections between the 578D equipment and the inter-connection board mounted on the operator, observing the diagram in fig.19.

A stop push-button, if any, must be located in series with respect to the connection between the STOP input of 578D and the SAFETY of the 541 INTERFACE. Refer to paragraph 6.3 for instructions on putting into operation.

4.8. Connection of operators without on-board interface

To make connections between the 578D equipment and operators without a on-board interface board, use the diagram figure 20. Refer to paragraph 6.2 for putting into operation, taking care over the limit-switch connections.

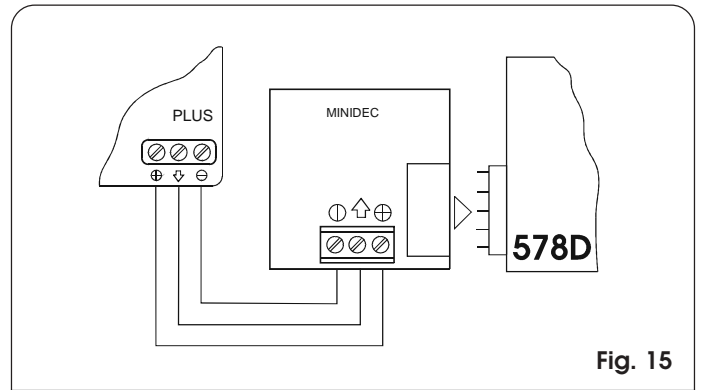

Fig. 15

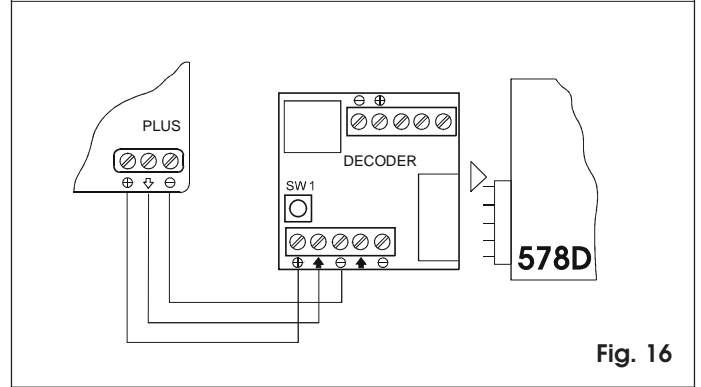

Fig. 16

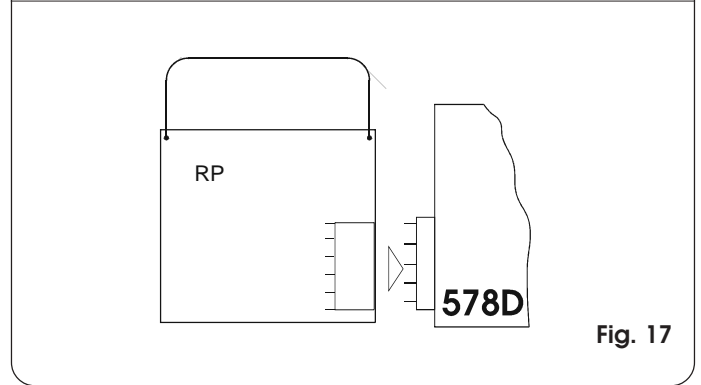

Fig. 17

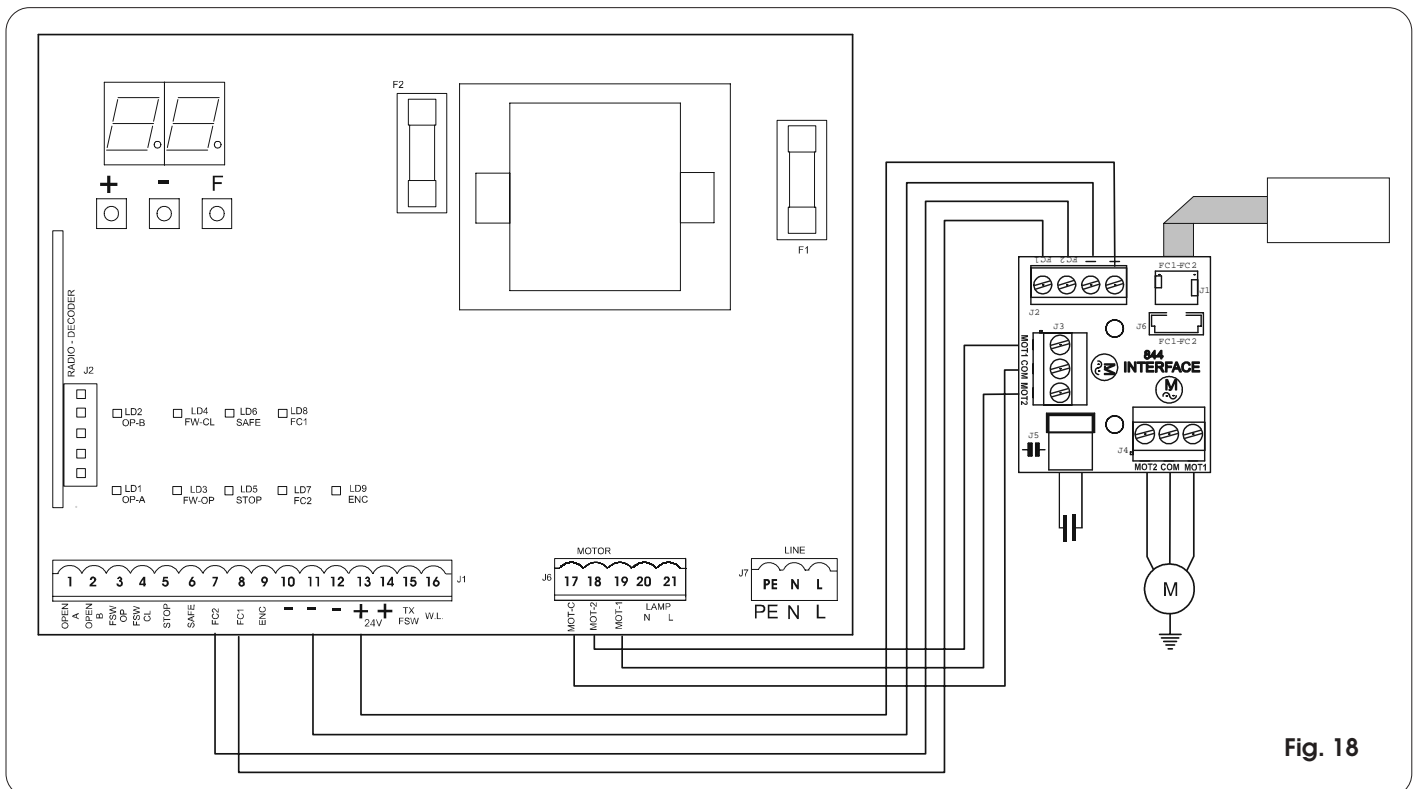

Fig. 18

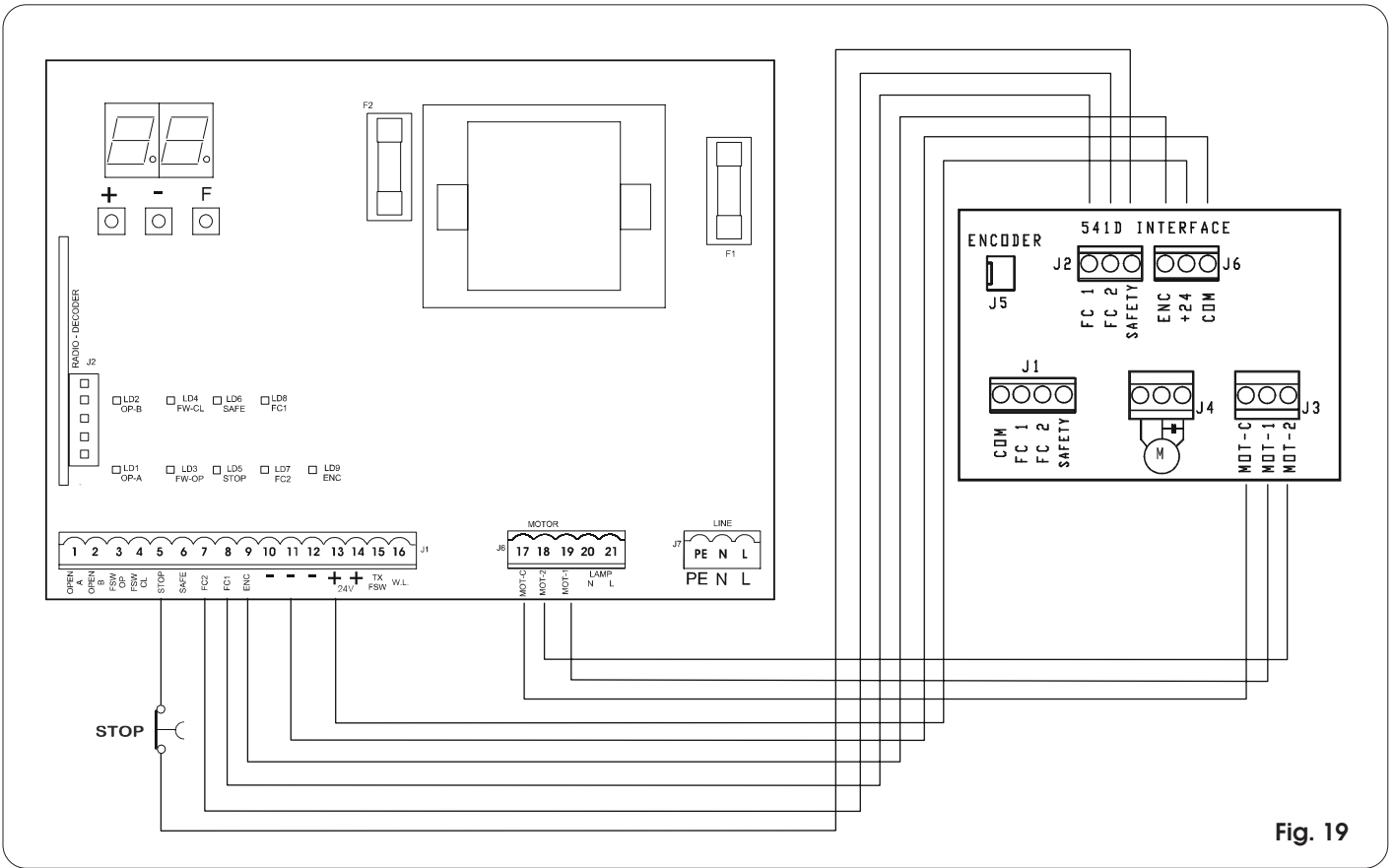

Fig. 19

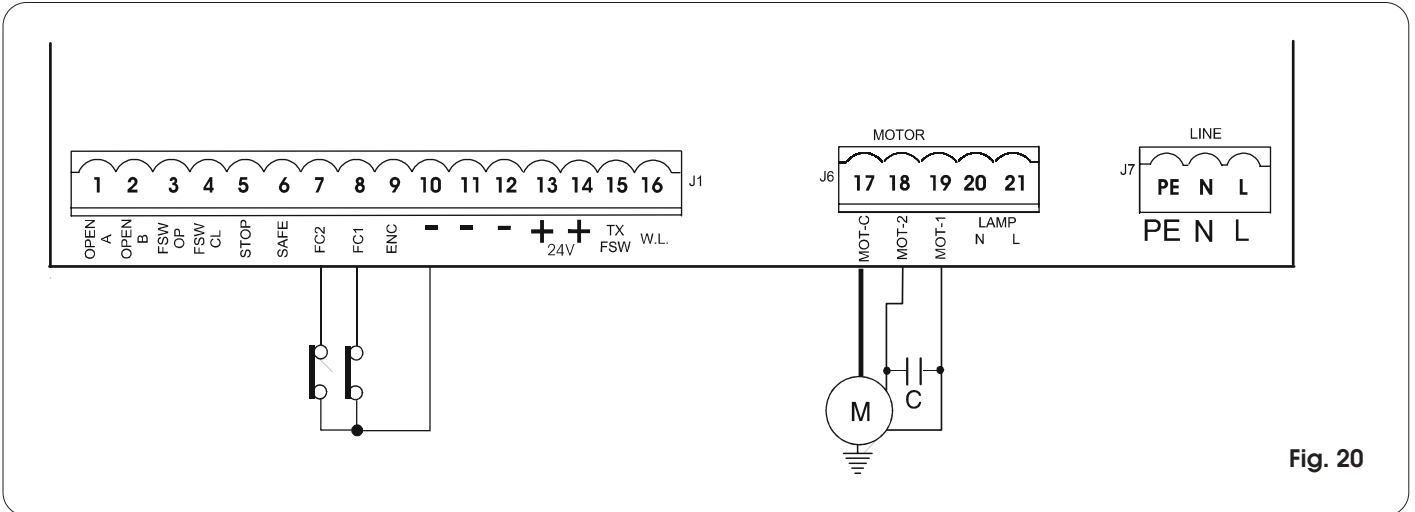

Fig. 20

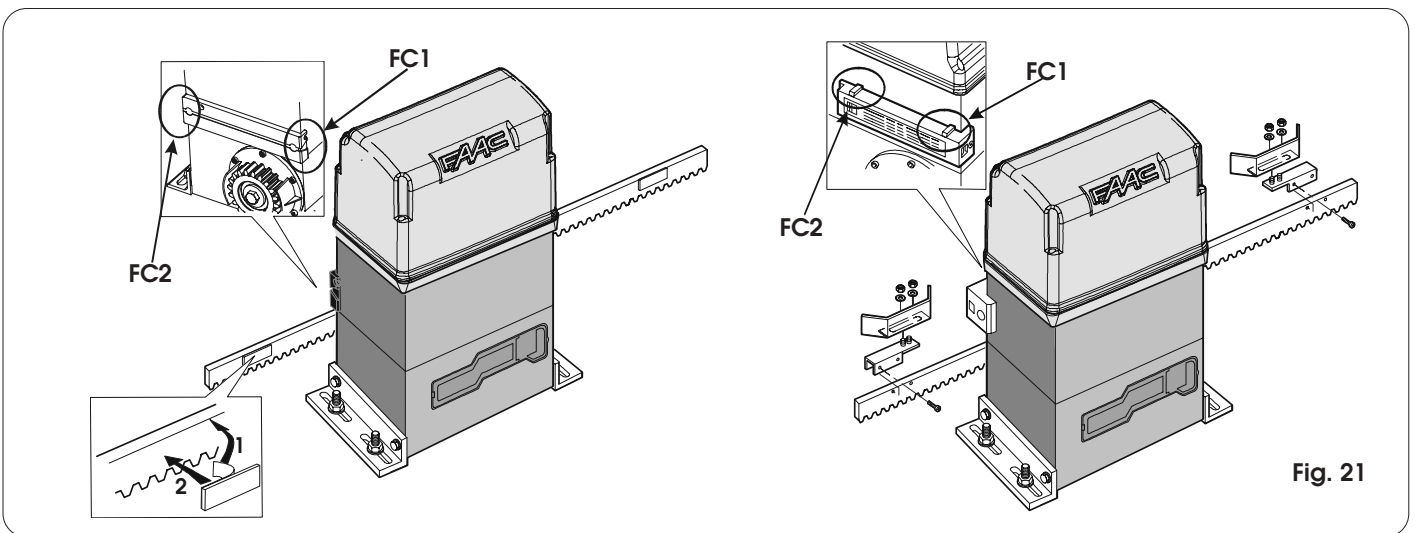

Fig. 21

5. PROGRAMMING

To program operation of the automated system, you have to access the "PROGRAMMING" mode.

Programming is split into two parts: BASIC and ADVANCED.

5.1. BASIC PROGRAMMING

To access BASIC PROGRAMMING, press key **F**:

- if you press it (and hold it down), the display shows the name of the first function.
- if you release the key, the display shows the value of the function that can be modified with keys **+** and **-**.
- if you press **F** again (and hold it down), the display shows the name of the next function, etc.
- when you reach the last function, press **F** to exit the program, and the display resumes showing the gate status.

The following table shows the sequence of functions accessible in BASIC PROGRAMMING:

BASIC PROGRAMMING (F)		
Display	Function	Default
LO	FUNCTION LOGICS (see table of logics): <i>A</i> = Automatic <i>AP</i> = "Stepped" automatic <i>S</i> = "Safety" Automatic <i>E</i> = Semi-automatic <i>EP</i> = "Stepped" Semi-automatic <i>C</i> = Dead-man <i>b</i> = "B" Semi-automatic <i>bc</i> = Mixed Log. (B opening / C closing)	EP
PA	PAUSE TIME: This has effect only if the automatic logic was selected. Adjustable from 0 to 59 sec. in one-second steps. Subsequently, display changes to minutes and tens of seconds (separated by a point) and time is adjusted in 10-second steps, up to the maximum value of 4.1 minutes. E.g. if the display shows 2.5, pause time is 2 min. and 50 sec.	2.0
FO	FORCE: Adjusts Motor thrust. 01 = minimum force 50 = maximum force	50
d1	OPENING DIRECTION: Indicates the gate opening movement and makes it possible not to change the motor and limit-switches connections on the terminal board. -3 = Standard opening movement E- = Reverse opening movement	-3
St	STATUS OF AUTOMATED SYSTEM: Exit from programming, save data, and return to gate status viewing. 00 = Closed 01 = Now opening 02 = At "STOP" 03 = Open 04 = Pause 05 = "FAIL SAFE" tripped 06 = Now closing 07 = Now reversing 08 = Photocells tripped	

5.2. ADVANCED PROGRAMMING

To access ADVANCED PROGRAMMING, press key **F** and, as you hold it down, press key **+**:

- if you release key **+**, the display indicates the name of the first function.
- if you release key **F** too, the display shows the value of the function that can be modified with keys **+** and **-**.
- if you press key **F** (and hold it down), the display shows the name of the next function, and if you release it, the value that can be modified with keys **+** and **-** is shown.
- when you reach the last function, press **F** to exit the program, and the display resumes showing the gate status.

The following table shows the sequence of functions accessible in ADVANCED PROGRAMMING:

ADVANCED PROGRAMMING (F + +)		
Display	Function	Default
bo	MAXIMUM TORQUE AT INITIAL THRUST: The motor operate at maximum torque (ignoring the torque setting) at start of movement. Useful for heavy leaves. 4 = Active no = Disabled	4
br	FINAL BRAKING: When the gate engages the opening or closing limit-switch, a braking stroke can be selected to ensure the leaf is stopped immediately. If decelerations are selected, braking starts when they finish. At 00 value, braking is disabled. Time can be adjusted from 01 to 20 in 0.01-second steps. 00 = Braking disabled from 01 to 20 = Timed braking	05
FS	FAIL SAFE: If this function is activated, it enables a function test of the photocells before any gate movement. If the test fails (photocells not serviceable signalled by value 05 on the display), the gate does not start moving. 4 = Active no = Disabled	no
PF	PRE-FLASHING (5s): Activates the flashing lamp for 5 seconds before start of movement. no = Disabled oP = Only before opening cL = Only before closing oC = Before every movement	no

Display	Function	Default
SP	<p>INDICATOR-LIGHT: If 00 is selected, the output functions as a standard indicator-light (lighted at opening and pause, flashing at closing, and off when gate closed).</p> <p>Courtesy light: Different figures correspond to timed activation of the output, which can be used (by a relay) to power a courtesy lamp. Time can be adjusted from 1 to 59 sec. in 1-second steps, and from 10 to 41 min. in 10-second steps.</p> <p>Electric lock command and 'traffic lights' functions: If you press key - from the 00 setting, the command for the E1 closing electric lock is activated; If you press - again, the command for the E2 closing and opening electric lock is set; if you press the - key again, you can set the 'traffic lights' functions E3 and E4. 00 = Standard indicator-light from 01 to 41 = Timed output. E1 = electric lock command before opening movement E2 = electric lock command before opening and closing movements E3 = 'traffic lights' function: the output is active in "open" and "open on pause" status and is disabled 3 seconds before the closing manoeuvre starts. Note: there is 3 seconds of pre-flashing before the closing manoeuvre. E4 = 'traffic lights' function: the output is active only in "closed" status. Attention: do not exceed the output's maximum load (24Vdc-3W). If necessary, use a relay and a power supply source outside the equipment.</p>	00
PH	<p>CLOSING PHOTOCELLS LOGIC: Select the tripping mode of the closing photocells. They operate for the closing movement only: they stop movement and reverse it when they are released, or they reverse it immediately. 1 = Reverse on release n0 = Reverse immediately to opening</p>	n0
OP	<p>OPENING PHOTOCELLS LOGIC: Select the tripping mode of the opening photocells. They operate for the opening movement only: they stop the movement and restart it when they are released, or they reverse it immediately. 1 = Reverse immediately to closing n0 = Restart movement on release</p>	n0

Display	Function	Default
EC	<p>ENCODER: If the encoder is used, you may select its presence. If the encoder is present and enabled, "decelerations" and "partial opening" are controlled by the encoder (see relevant paragraphs). The encoder operates as an anti-crushing device: If the gate strikes an obstacle during opening or closing, the encoder immediately reverses gate leaf movement for 2 seconds. If the encoder operates again during the 2-seconds reversing time, it stops movement (STOP) without commanding any reversing. If no sensor is supplied, the parameter must be set on 00. If there is the encoder, adjust the sensitivity of the anti-crushing system, by varying the parameter between 01 (maximum sensitivity) and 99 (minimum sensitivity). from 01 to 99 = Encoder active and sensitivity adjustment 00 = Encoder disabled</p>	00
RP	<p>Pre-limit switch DECELERATION: You can select gate deceleration before the opening and closing limit-switches have been tripped. Time can be adjusted from 00 to 99 in 0.04-second steps. If an encoder is used, the adjustment is not determined by time but by motor revs, thus obtaining greater deceleration precision. 00 = Deceleration disabled from 01 to 99 = Deceleration enabled</p>	00
RA	<p>Post-limit switch DECELERATION: You can select gate deceleration after the opening and closing limit-switches have been tripped. Time can be adjusted from 00 to 20 in 0.02-second steps. If an encoder is used, the adjustment is not determined by time but by motor revs, thus obtaining greater deceleration precision. 00 = Deceleration disabled from 01 to 20 = Deceleration enabled</p>	05
PO	<p>PARTIAL OPENING: You can adjust the width of partial leaf opening. Time can be adjusted from 01 to 20 in 1-second steps. If an encoder is used, the adjustment is not determined by time but by motor revs, thus obtaining greater partial-opening precision. For example, with pinion Z20, partial opening can vary from about 60 cm to 4 m.</p>	05

Display	Function	Default
E	<p>WORKTIME (time-out): We advise you to set a value of 5 to 10 seconds over the time taken by the gate to travel from the closing limit-switch to the opening limit-switch and vice versa. Adjustable from 0 to 59 sec. in one-second steps. Subsequently, display changes to minutes and tens of seconds (separated by a point) and time is adjusted in 10 second steps, up to a maximum value of 4.1 minutes.</p> <p>Attention: the set value does not exactly match the motor's maximum operating time, because the latter is modified according to the performed deceleration spaces.</p>	4.1
AS	<p>ASSISTANCE REQUEST (combined with next function): If activated, at the end of countdown (settable with the next function i.e. "Cycle programming") it effects 2 sec. (in addition to the value already set with the PF function) of pre-flashing at every Open pulse (job request). Can be useful for setting scheduled maintenance jobs. 4 = Active no = Disabled</p>	no
nc	<p>CYCLE PROGRAMMING: For setting countdown of system operation cycles. Settable (in thousands) from 00 to 99 thousand cycles. The displayed value is updated as cycles proceed. This function can be used to check use of the board or to exploit the "Assistance request".</p>	00
SE	<p>GATE STATUS: Exit from programming, data saving, and return to viewing gate status (see par. 5.1.).</p>	

NB.: modification of programming parameters comes into effect immediately, whereas definitive memory storage occurs only when you exit programming and return to gate status viewing. If the equipment is powered down before return to status viewing, all modifications will be lost.
To restore the default settings of the programming disconnect terminal strip J1, press the three buttons +, -, F simultaneously and keep them pressed for 5 seconds.

6. START-UP

6.1. Inputs check

The table below shows the status of the LEDs in relation to the status of the inputs.

Note the following: **LED LIGHTED** = closed contact

LED OFF = open contact

Check the status of the LEDs as per Table.

Operation of the signalling status LEDs

LEDS	LIGHTED	OFF
OP-A	Command activated	Command inactive
OP-B	Command activated	Command inactive
FC1	Limit-switch free	Limit-switch engaged
FC2	Limit-switch free	Limit-switch engaged
FW OP	Safety devices disengaged	Safety devices engaged
FW CL	Safety devices disengaged	Safety devices engaged
STOP	Command inactive	Command activated
SAFE	Safety devices disengaged	Safety devices engaged
ENC	Flashes while the motor rotates	

NB.:

- The status of the LEDs while the gate is closed at rest are shown in bold.
- If the Encoder sensor is not installed, the ENC LED is always OFF.
- If you select the reverse opening direction (see par.5.1), the operation of the limit-switches is also reversed. Therefore, in closed status, the engaged limit-switch will be FC1 (LED OFF).

6.2. Installation using sliding gate operators

When you have made the connections between the 578D equipment and the on-board operator interface board, and have fitted the travel-limit plates on the rack (see operator instructions), check opening direction and limit-switch efficiency, as follows:

- Power up the system.
- Select the opening direction (see par.5.1.). If you look at the gate from the side where the operator is installed, the opening movement should be from left to right - if it is, select the standard direction, otherwise select the reverse direction.
- Set parameter EC on 00 (see par.5.2).
- When you made the modifications, exit programming, return to inputs viewing and then power down and power up the system.
- Release the operator and, sliding the gate manually, check the efficiency of the limit-switches, controlling the status LEDs of the inputs (see par.6.1). If you look at the gate from the side where the operator is installed, the FC1 LED should go off when the stop position of the left to right movement is reached, and FC2 should go off when the stop position of the right to left movement is reached (also see fig.21).
- Lock the operator about midway along its travel.
- Give an OPEN A command and check if the gate moves in opening direction. If it does not, lock the movement and, after cutting the power to the system, change over the wires connected to terminals of MOT-1 and MOT-2.

NOTE-For motors with an inductive sensor (746 and 844) take care over setting post-limit-switch deceleration and braking: if deceleration is too long or braking is insufficient, the plate fitted on the gate rack can go beyond the sensor until it disengages the sensor. When the gate is stopped, check if only the limit-switch involved is engaged. The relevant LED must be off. If it went off and then re-lighted, or if both the LEDs of the limit-switches are off, reduce the post-limit-switch deceleration value and/or increase braking value.

6.3. Installation using the 541 operator

When you have made the connections between the 578D equipment and the on-board operator interface board, and have adjusted the limit-switches (see operator instructions), check opening direction as follows:

- Cut power to the system.
- Release the operator and partially open the door.
- Lock the operator, power up the system again and command opening. If the door begins its closing movement, change opening direction (see Par.5.1). After you have changed it, return to viewing automated system status, and then power down and power up the equipment.

NOTE- For perfect installation of the 578D equipment, using sectional doors operator 541, take care over the following aspects:

OPENING DECELERATION: the reduction of the operator's speed during deceleration also reduces the force it can deliver. If the door is not well balanced, 541 may not be able to perform deceleration at end of opening (door with strong tendency to close) or closing (door with strong tendency to open), because the delivered force is not sufficient to overcome the imbalance. In this case, 0 must be set as the pre- and post-limit-switch deceleration value (see advanced programming in Par.5.2), because a different value could prevent the limit-switch being reached or prevent reversal of motion following tripping of the anti-crushing system.

ANTI-CRUSHING SAFETY DEVICE DURING CLOSING: although it has an Encoder sensor, the 541 operator cannot intrinsically guarantee this safety device, because it is not fitted directly on the door, but acts on the rope winding shaft. Therefore, the ENCODER sensor cannot detect any obstacle during closing. In this connection, we recommend to observe current legal regulations for protecting the lower part of the door.

7. FINAL OPERATIONS

At end of programming, run a few complete cycles to check if the automated system and the accessories connected to it are operating correctly, giving special attention to safety devices, operator thrust force adjustment, and to the anti-crushing device (Encoder sensor). Hand over the "User's guide" page (in the operator instructions) to the customer, and describe how the system works, as well as the operator release and locking operations indicated in the said guide.

Tab. 3/a

PULSES					
Logic "A"	OPEN-A	OPEN-B	STOP	OPENING SAFETY DEVICES	CLOSING SAFETY DEVICES
GATE STATUS					
CLOSED	Opens the leaf and closes it after pause time (1)	Opens leaf for the partial opening time and closes after pause time (1)		No effect (OPEN disabled)	No effect
OPEN on PAUSE	Reloads pause time (1)(3)			No effect (if on part.opng. OPEN A disabled)	Reloads pause time (1) (3)
CLOSING	Re-opens the leaf immediately (1)		Stops operation	No effect (saves OPEN)	Reloads pause time (1) (3) see paragraph 5.2.
OPENING	No effect (1) (3)			see paragraph 5.2.	No effect
LOCKED	Closes the leaf (3)		No effect (OPEN disabled)		No effect (OPEN disabled)

Tab. 3/b

PULSES					
Logic "AP"	OPEN-A	OPEN-B	STOP	OPENING SAFETY DEVICES	CLOSING SAFETY DEVICES
GATE STATUS					
CLOSED	Opens the leaf and closes it after pause time	Opens leaf for the partial opening time and closes after pause time		No effect (OPEN disabled)	No effect
OPEN on PAUSE	Stops operation (3)			No effect (if on part.opng. OPEN A disabled)	Reloads pause time (3)
CLOSING	Re-opens the leaf immediately		Stops operation	No effect (saves OPEN)	Reloads pause time (3) see paragraph 5.2.
OPENING	Stops operation (3)			see paragraph 5.2.	No effect
LOCKED	Closes the leaf (with Closing Safety devices engaged, opens at the 2nd pulse) (3)		No effect (OPEN disabled)		No effect (OPEN disabled)

Tab. 3/c

PULSES					
Logic "S"	OPEN-A	OPEN-B	STOP	OPENING SAFETY DEVICES	CLOSING SAFETY DEVICES
GATE STATUS					
CLOSED	Opens the leaf and closes it after pause time	Opens leaf for the partial opening time and closes after pause time		No effect (OPEN disabled)	No effect
OPEN on PAUSE	Re-closes the leaf immediately (3)			No effect (if on part.opng. OPEN A disabled)	On release, closes after 5" (OPEN disabled) (3)
CLOSING	Re-opens the leaf immediately		Stops operation	No effect (saves OPEN)	see paragraph 5.2.
OPENING	Re-closes the leaf immediately (3)			see paragraph 5.2.	No effect (saves OPEN)
LOCKED	Closes the leaf (3)		No effect (OPEN disabled)		No effect (OPEN disabled)

Tab. 3/d

PULSES					
Logic "E"	OPEN-A	OPEN-B	STOP	OPENING SAFETY DEVICES	CLOSING SAFETY DEVICES
GATE STATUS					
CLOSED	Opens the leaf	Opens leaf for the partial opening time		No effect (OPEN disabled)	No effect
OPEN	Re-closes the leaf immediately (3)			No effect (if on part.opng. OPEN A disabled)	No effect (3)
CLOSING	Re-opens the leaf immediately		Stops operation	No effect (saves OPEN)	see paragraph 5.2.
OPENING	Stops operation (3)			see paragraph 5.2.	No effect
LOCKED	Closes the leaf (with Closing Safety devices engaged, opens at the 2nd pulse) (3)		No effect (OPEN disabled)		No effect (OPEN disabled)

Tab. 3/e

PULSES					
Logic "EP"	OPEN-A	OPEN-B	STOP	OPENING SAFETY DEVICES	CLOSING SAFETY DEVICES
GATE STATUS					
CLOSED	Opens the leaf	Opens leaf for the partial opening time		No effect (OPEN disabled)	No effect
OPEN	Re-closes the leaf immediately (3)		Stops operation	No effect (if on part.opng. OPEN A disabled)	No effect (OPEN disabled) (3)
CLOSING	Stops operation			No effect (saves OPEN)	see paragraph 5.2.
OPENING	Stops operation (3)			see paragraph 5.2.	No effect
LOCKED	Restarts movement in reverse direction (3) (always closes after a Stop)		No effect (OPEN disabled)	No effect (if it must open, it disables OPEN)	No effect (if it must close, it disables OPEN)
					No effect (OPEN disabled)
					Locks and, on release, reverses to open
					Locks and, on release, continues opening
					Reverses to open for 2" (2)
					Reverses to close for 2" (2)

Tab. 3/f

PULSES					
CONTROLS ALWAYS HELD DOWN					
Logic "C"	OPEN-A (opening)	OPEN-B (closing)	STOP	OPENING SAFETY DEVICES	CLOSING SAFETY DEVICES
GATE STATUS					
CLOSED	Opens the leaf	No effect (OPEN-A disabled)		No effect (OPEN A disabled)	No effect (OPEN A disabled)
OPEN	No effect (OPEN-B disabled)	Closes the leaf	No effect (OPEN-A/B disabled)	No effect (OPEN A disabled)	No effect (OPEN B disabled)
CLOSING	Stops operation	/	Stops operation	No effect	Stops operation (OPEN-B disabled)
OPENING	/	Stops operation		Stops operation (OPEN-A disabled)	No effect
					Stops operation (OPEN-A/B disabled)
					Reverses to open for 2" (2)
					Reverses to close for 2" (2)

Tab. 3/g

PULSES					
Logic "B"	OPEN-A (opening)	OPEN-B (closing)	STOP	OPENING SAFETY DEVICES	CLOSING SAFETY DEVICES
GATE STATUS					
CLOSED	Opens the leaf	No effect		No effect (OPEN A disabled)	No effect (OPEN A disabled)
OPEN	No effect	Closes the leaf	No effect (OPEN B disabled)	No effect	No effect (OPEN B disabled)
CLOSING	Reverses to open	No effect	Stops operation	No effect (saves OPEN A)	Stops operation (OPEN-B disabled)
OPENING	No effect	No effect		Stops operation (OPEN-A disabled)	No effect
LOCKED	Opens the leaf	Closes the leaf	No effect (OPEN A/B disabled)	No effect (OPEN-A disabled)	No effect (OPEN B disabled)
					Stops operation (OPEN-A/B disabled)
					Reverses to open for 2" (2)
					Reverses to close for 2" (2)

Tab. 3/h

PULSES					
OPENING PULSE/CLOSING HOLD TO RUN CONTROLS					
Logic "B/C"	OPEN-A (opening)	OPEN-B (closing)	STOP	OPENING SAFETY DEVICES	CLOSING SAFETY DEVICES
GATE STATUS					
CLOSED	Opens the leaf	No effect		No effect (OPEN A disabled)	No effect (OPEN A disabled)
OPEN	No effect	Closes the leaf	No effect (OPEN B disabled)	No effect	No effect (OPEN B disabled)
CLOSING	Reverses to open	No effect	Stops operation	No effect (saves OPEN A)	Stops operation (OPEN-B disabled)
OPENING	No effect	No effect		Stops operation (OPEN-A disabled)	No effect
LOCKED	Opens the leaf	Closes the leaf	No effect (OPEN A/B disabled)	No effect (OPEN-A disabled)	No effect (OPEN B disabled)
					Stops operation (OPEN-A/B disabled)
					Reverses to open for 2" (2)
					Reverses to close for 2" (2)

(1) If maintained, it prolongs the pause until disabled by the command (timer function)
 (2) If a new pulse occurs within 2 seconds after reversing, it immediately stops operation. **NB.:** Effects on other active pulse inputs in brackets.
 (3) During the partial opening cycle, an OPEN A pulse causes total opening.