



CE

119AS45EN

UNDERGROUND OPERATOR
FOR SWING GATES

Official Partner



MILANO 2015

FEEDING THE PLANET
ENERGY FOR LIFE



Installation manual

FROG-A / FROG-AV / FROG-AE



English

EN



WARNING! important safety instructions: READ CAREFULLY!



PREMISE

• EMPLOY THIS PRODUCT ONLY FOR THE USE FOR WHICH IT WAS EXPRESSLY MADE. ANY OTHER USE IS DANGEROUS. CAME S.p.A. IS NOT LIABLE FOR ANY DAMAGE CAUSED BY IMPROPER, WRONGFUL AND UNREASONABLE USE • KEEP THESE WARNINGS TOGETHER WITH THE INSTALLATION AND OPERATION MANUALS THAT COME WITH THE OPERATOR.

BEFORE INSTALLING

(CHECKING WHAT'S THERE: IF YOUR EVALUATION IS NEGATIVE, DO NOT PROCEED BEFORE HAVING COMPLIED WITH ALL SAFETY REQUIREMENTS)

• CHECK THAT THE AUTOMATED PARTS ARE IN GOOD MECHANICAL ORDER, THAT THE OPERATOR IS LEVEL AND ALIGNED, AND THAT IT OPENS AND CLOSES PROPERLY. MAKE SURE YOU HAVE SUITABLE MECHANICAL STOPS • IF THE OPERATOR IS TO BE INSTALLED AT A HEIGHT OF OVER 2.5 M FROM THE GROUND OR OTHER ACCESS LEVEL, MAKE SURE YOU HAVE ANY NECESSARY PROTECTIONS AND/OR WARNINGS IN PLACE • IF ANY PEDESTRIAN OPENINGS ARE FITTED INTO THE OPERATOR, THERE MUST ALSO BE A SYSTEM TO BLOCK THEIR OPENING WHILE THEY ARE MOVING • MAKE SURE THAT THE OPENING AUTOMATED DOOR OR GATE CANNOT ENTRAP PEOPLE AGAINST THE FIXED PARTS OF THE OPERATOR • DO NOT INSTALL THE OPERATOR UPSIDE DOWN OR ONTO ELEMENTS THAT COULD YIELD AND BEND. IF NECESSARY, ADD SUITABLE REINFORCEMENTS TO THE ANCHORING POINTS • DO NOT INSTALL DOOR OR GATE LEAVES ON TILED SURFACES • MAKE SURE ANY SPRINKLER SYSTEMS CANNOT WET THE OPERATOR FROM THE GROUND UP • MAKE SURE THE TEMPERATURE RANGE SHOWN ON THE PRODUCT LITERATURE IS SUITABLE TO THE CLIMATE WHERE IT WILL BE INSTALLED • FOLLOW ALL INSTRUCTIONS AS IMPROPER INSTALLATION MAY RESULT IN SERIOUS BODILY INJURY • IT IS IMPORTANT TO FOLLOW THESE INSTRUCTIONS FOR THE SAFETY OF PEOPLE. KEEP THESE INSTRUCTIONS.

INSTALLING

• SUITABLY SECTION OFF AND DEMARCATO THE ENTIRE INSTALLATION SITE TO PREVENT UNAUTHORIZED PERSONS FROM ENTERING THE AREA, ESPECIALLY MINORS AND CHILDREN • BE CAREFUL WHEN HANDLING OPERATORS THAT WEIGH OVER 20 KG. IF NEED BE, USE PROPER SAFETY HOISTING EQUIPMENT • ALL OPENING COMMANDS (THAT IS, BUTTONS, KEY SWITCHES, MAGNETIC READERS, AND SO ON) MUST BE INSTALLED AT LEAST 1.85 M FROM THE PERIMETER OF THE GATE'S WORKING AREA, OR WHERE THEY CANNOT BE REACHED FROM OUTSIDE THE GATE. ALSO, ANY DIRECT COMMANDS (BUTTONS, TOUCH PANELS, AND SO ON) MUST BE INSTALLED AT LEAST 1.5 M FROM THE GROUND AND MUST NOT BE REACHABLE BY UNAUTHORIZED PERSONS • ALL MAINTAINED ACTION COMMANDS, MUST BE FITTED IN PLACES FROM WHICH THE MOVING GATE LEAVES AND TRANSIT AND DRIVING AREAS ARE VISIBLE • APPLY, IF MISSING, A PERMANENT SIGN SHOWING THE POSITION OF THE RELEASE DEVICE • BEFORE DELIVERING TO THE USERS, MAKE SURE THE SYSTEM IS EN 12453 STANDARD COMPLIANT (REGARDING IMPACT FORCES), AND ALSO MAKE SURE THE SYSTEM HAS BEEN PROPERLY ADJUSTED AND THAT ANY SAFETY, PROTECTION AND MANUAL RELEASE DEVICES ARE WORKING PROPERLY • APPLY WARNING SIGNS (SUCH AS THE GATE'S PLATE) WHERE NECESSARY AND IN A VISIBLE PLACE

SPECIAL USER-INSTRUCTIONS AND RECOMMENDATIONS

• KEEP GATE OPERATION AREAS CLEAN AND FREE OF ANY OBSTRUCTIONS. MAKE SURE THAT THE PHOTOCELLS ARE FREE OF ANY OVERGROWN VEGETATION AND THAT THE OPERATOR'S AREA OF OPERATION IS FREE OF ANY OBSTRUCTIONS • DO NOT ALLOW CHILDREN TO PLAY WITH FIXED COMMANDS, OR TO LOITER IN THE GATE'S MANEUVERING AREA. KEEP ANY REMOTE CONTROL TRANSMITTERS OR ANY OTHER COMMAND DEVICE AWAY FROM CHILDREN, TO PREVENT THE OPERATOR FROM BEING ACCIDENTALLY ACTIVATED. • THE APPARATUS MAY BE USED BY CHILDREN OF EIGHT YEARS AND ABOVE AND BY PHYSICALLY, MENTALLY AND SENSORIALLY CHALLENGED PEOPLE, OR EVEN ONES WITHOUT ANY EXPERIENCE, PROVIDED THIS HAPPENS UNDER CLOSE SUPERVISION OR ONCE THEY HAVE BEEN PROPERLY INSTRUCTED TO USE THE APPARATUS SAFELY AND ABOUT THE POTENTIAL HAZARDS INVOLVED. CHILDREN MUST NOT PLAY WITH THE APPARATUS. CLEANING AND MAINTENANCE BY USERS MUST NOT BE DONE BY CHILDREN, UNLESS PROPERLY SUPERVISED • FREQUENTLY CHECK THE SYSTEM FOR ANY MALFUNCTIONS OR SIGNS OF WEAR AND TEAR OR DAMAGE TO THE MOVING STRUCTURES, TO THE COMPONENT PARTS, ALL ANCHORING POINTS, INCLUDING CABLES AND ANY ACCESSIBLE CONNECTIONS. KEEP ANY HINGES, MOVING JOINTS AND SLIDE RAILS PROPERLY LUBRICATED • PERFORM FUNCTIONAL CHECKS ON THE PHOTOCELLS AND SENSITIVE SAFETY EDGES, EVERY SIX MONTHS. TO CHECK WHETHER THE PHOTOCELLS ARE WORKING, WAVE AN OBJECT IN FRONT OF THEM WHILE THE GATE IS CLOSING; IF THE OPERATOR INVERTS ITS DIRECTION OF TRAVEL OR SUDDENLY STOPS, THE PHOTOCELLS ARE WORKING PROPERLY. THIS IS THE ONLY MAINTENANCE OPERATION TO DO WITH THE POWER ON. CONSTANTLY CLEAN THE PHOTOCELLS' GLASS COVERS USING A SLIGHTLY WATER-MOISTENED CLOTH; DO NOT USE ANY SOLVENTS OR OTHER CHEMICAL PRODUCTS THAT MAY RUIN THE DEVICES • IF REPAIRS OR MODIFICATIONS ARE REQUIRED TO THE SYSTEM, RELEASE THE OPERATOR AND DO NOT USE IT UNTIL SAFETY CONDITIONS HAVE BEEN RESTORED • CUT OFF THE POWER SUPPLY BEFORE RELEASING THE OPERATOR FOR MANUAL OPENINGS AND BEFORE ANY OTHER OPERATION, TO

PREVENT POTENTIALLY HAZARDOUS SITUATIONS. READ THE INSTRUCTIONS • IF THE POWER SUPPLY CABLE IS DAMAGED, IT MUST BE REPLACED BY THE MANUFACTURER OR AUTHORIZED TECHNICAL ASSISTANCE SERVICE, OR IN ANY CASE, BY SIMILARLY QUALIFIED PERSONS, TO PREVENT ANY RISK • IT IS FORBIDDEN FOR USERS TO PERFORM ANY OPERATIONS THAT ARE NOT EXPRESSLY REQUIRED OF THEM AND WHICH ARE NOT LISTED IN THE MANUALS. FOR ANY REPAIRS, MODIFICATIONS AND ADJUSTMENTS AND FOR EXTRAORDINARY MAINTENANCE, CALL TECHNICAL ASSISTANCE • LOG THE JOB AND CHECKS INTO THE PERIODIC MAINTENANCE LOG.

ADDITIONAL SPECIAL RECOMMENDATIONS FOR EVERYONE

• KEEP AWAY FROM HINGES AND MECHANICAL MOVING PARTS • DO NOT ENTER THE OPERATOR'S AREA OF OPERATION WHEN IT IS MOVING • DO NOT COUNTER THE OPERATOR'S MOVEMENT AS THIS COULD RESULT IN DANGEROUS SITUATIONS • ALWAYS PAY SPECIAL ATTENTION TO ANY DANGEROUS POINTS, WHICH HAVE TO BE LABELED WITH SPECIFIC PICTOGRAMS AND/OR BLACK AND YELLOW STRIPES • WHILE USING A SELECTOR SWITCH OR A COMMAND IN MAINTAINED ACTIONS, KEEP CHECKING THAT THERE ARE NO PERSONS WITHIN THE OPERATING RANGE OF ANY MOVING PARTS, UNTIL THE COMMAND IS RELEASED • THE GATE MAY MOVE AT ANY TIME AND WITHOUT WARNING • ALWAYS CUT OFF THE POWER SUPPLY BEFORE PERFORMING ANY MAINTENANCE OR CLEANING.

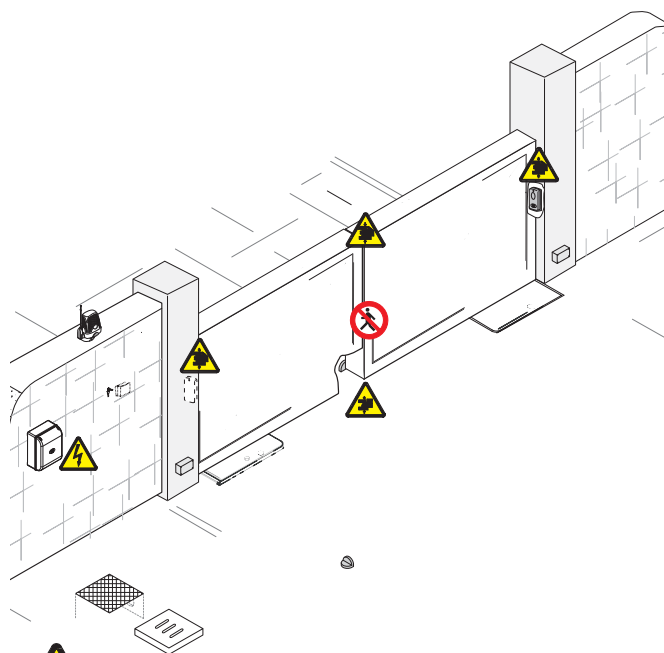

Danger of foot crushing



Hand crushing hazard





Danger high voltage



No transit during operation

KEY

-  This symbol indicates parts to read carefully.
-  This symbol indicates parts about safety.
-  This symbol tells you what to say to the end users.

THE MEASUREMENTS, UNLESS OTHERWISE STATED, ARE IN MILLIMETERS.

DESCRIPTION

The product consists of: a foundation box, a gearmotor and motion transmission arms.

Intended use

Designed to power swing gates for residential or condominium use.

-  Any installation and operation that differs from what is set out in this manual is prohibited.

Limits of use

Model	FROG-A / FROG-AE		
Max. leaf length (m)	3.5	2.5	2.0
Max. leaf weight (kg)	400	600	800
Model	FROG-AV		
Max. leaf length (m)	1.3		
Max. leaf weight (kg)	300		

With swing gates it is always advisable to install and electro-lock. This is to ensure a reliable closing and to protect the gearmotor's inner workings. But whereas with reversible operators it is merely advisable, with irreversible ones, beyond 2.5 m, it is obligatory.

Technical data

Type	FROG-A / FROG-AE	FROG-AV
Protection rating (IP)	67	67
Power supply (V - 50/60 Hz)	230 AC	230 AC
Motor power supply (V - 50/60 Hz)	230 AC	230 AC
Power draw (A)	1.9 max.	2.5 max.
Power (W)	200	300
Thrust (N)	320 max.	240 max.
Opening time to 90° (sec)	18	9
Duty Cycle (%)	30%	30%
Operating temperature (°C)	-20 - +55	-20 - +55
Motor thermal protection (°C)	150	150
Gear ratio	1/1152	1/1152
Insulation class	I	I
Weight (kg)	11	11

Packing list

1. 1 x Gearmotor
2. 1 x UNI 5588 M8 nut
3. 1 x UNI 5739 M4 x 100 screw
4. 1 x Transmission lever
5. 1 x installation manual

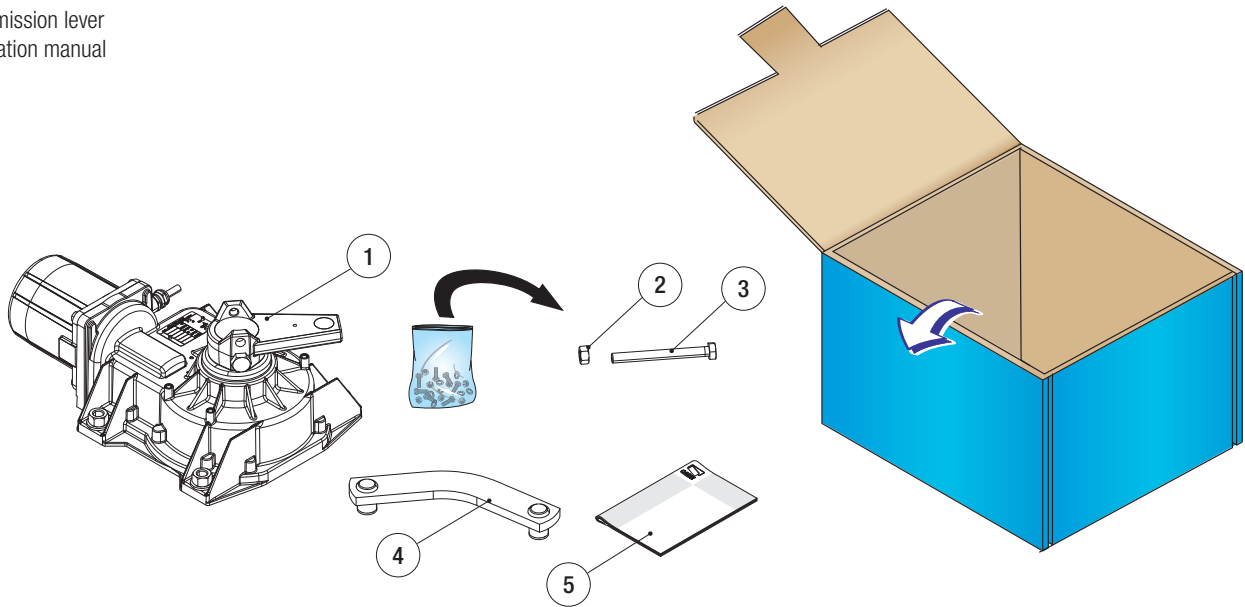

Description of the components

1. Gearmotor
2. Transmission lever
3. Gearmotor arm
4. Limit switch adjusting screw when closing
5. Couple release lever
6. Mounting bracket to gate
7. Limit switch adjusting screw when closing
8. Foundation box
9. Casing hole
10. Cover fixing screw
11. UNI 5588 M12 nut
12. UNI 6592 12 washer
13. Drainage hole
14. Cable routing hole
15. Pin

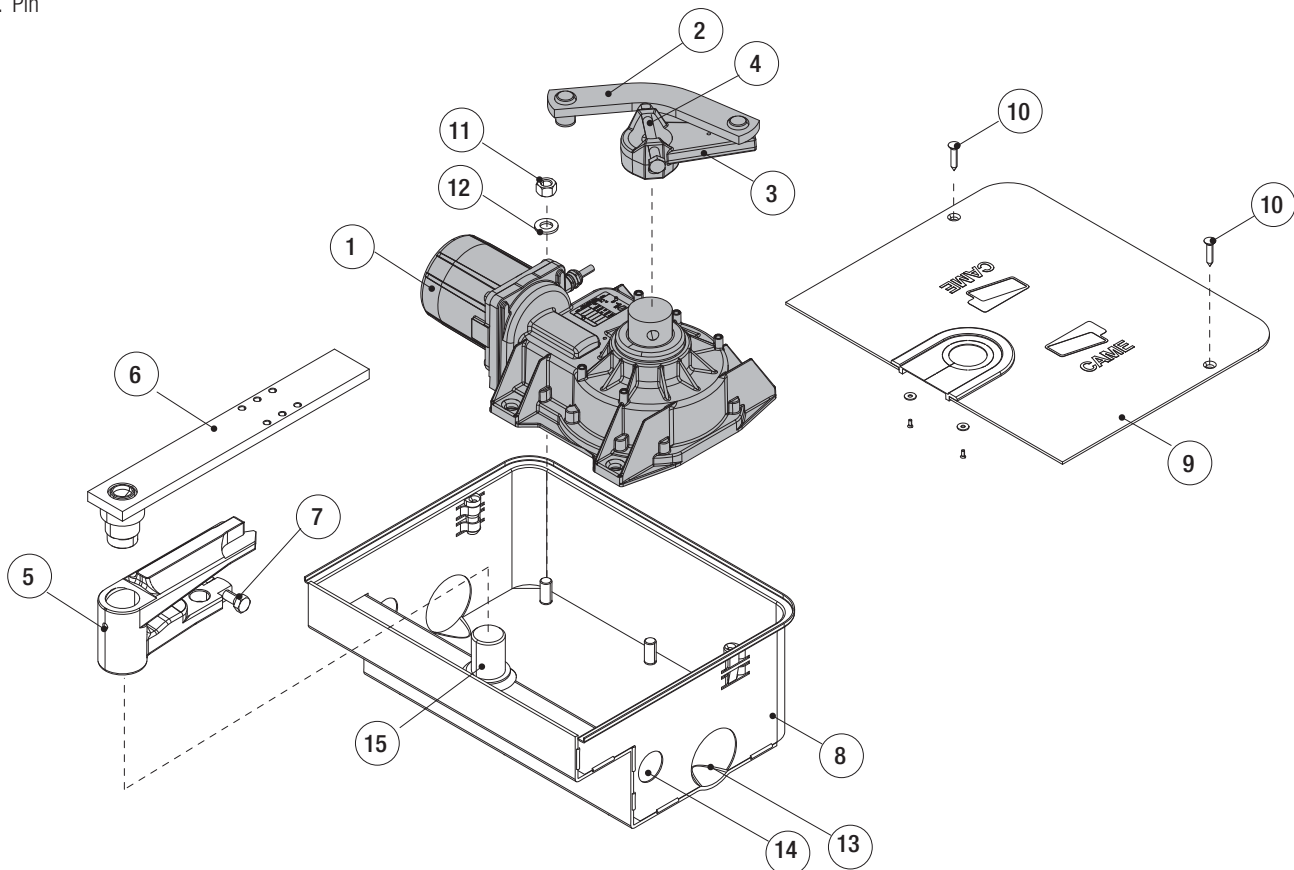

Example of a system

1. Gearmotor with foundation box
2. Control panel
3. Junction box
4. Key selector
5. Antenna
6. Flashing light
7. Photocells
8. Photocell post
9. Latch
10. Inspection chamber
11. Drainage chamber
12. Mechanical stop

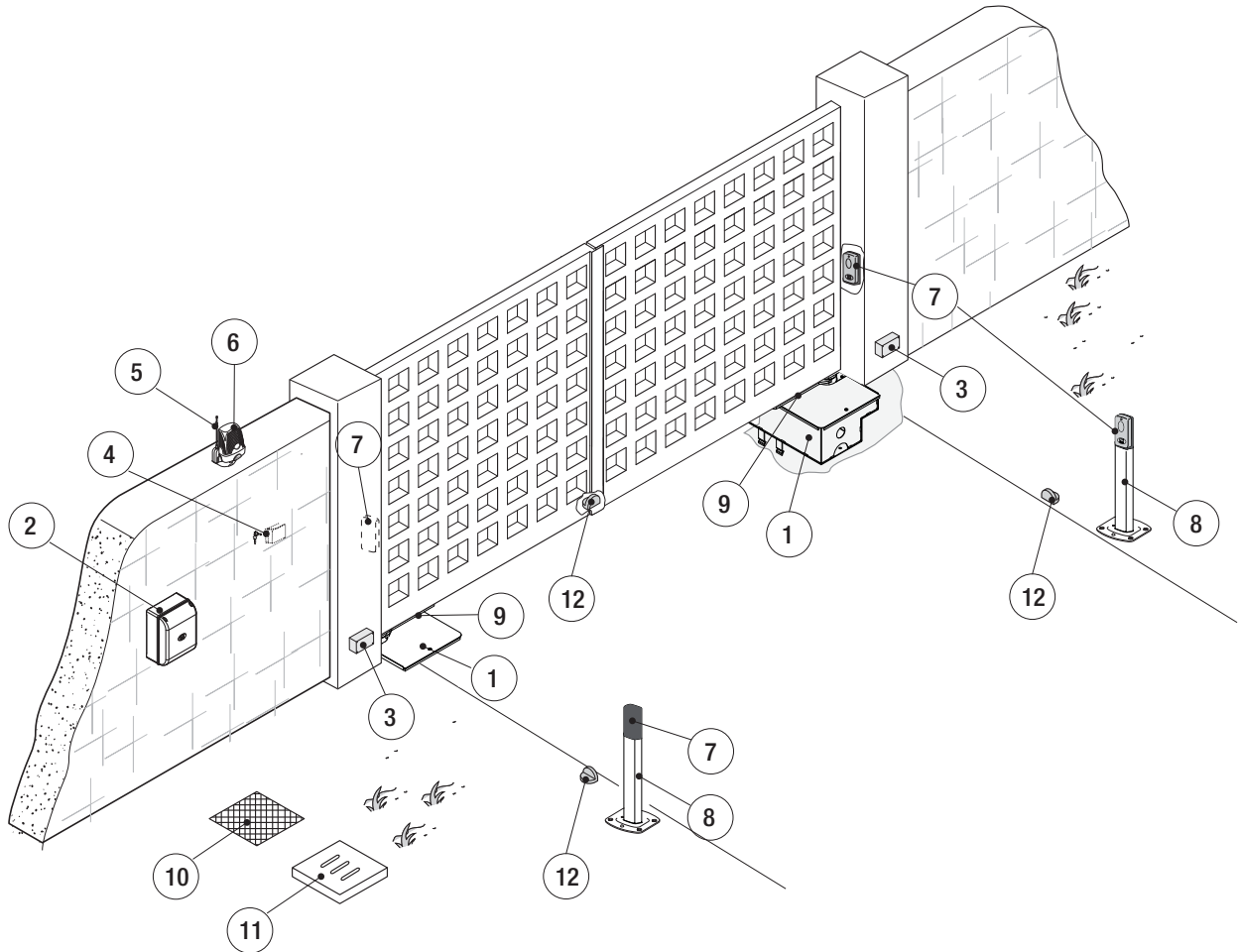

Dimensions

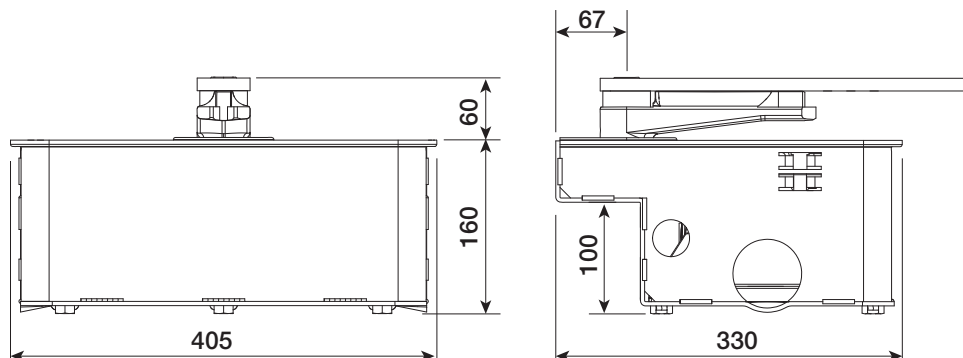

GENERAL INSTALLATION INSTRUCTIONS

△ Installation must be carried out by qualified and experienced personnel in compliance with applicable regulations.

Preliminary checks

△ Before installing the operator:

- Provide a suitable single-pole disconnection device, with a maximum of 3 mm between the contacts, to disconnect the power supply;
- Prepare suitable piping and ducts for routing the electrical cables, ensuring protection against mechanical damage;
- Prepare a drain pipe to prevent stagnation that may cause oxidation;
- ⊕ Make sure that any connections within the container (made to ensure the continuity of the protection circuit) are fitted with additional insulation compared to the other internal conductor parts;
- Make sure the gate structure is sturdy enough, that the hinges are in proper working order and that there is no friction between the moving and fixed parts;
- Make sure there are opening and closing mechanical stops.

Tools and materials

Make sure you have all the tools and materials you will need for the installation at hand to work in total safety and compliance with current standards and regulations. The figure shows some examples of installer's tools.

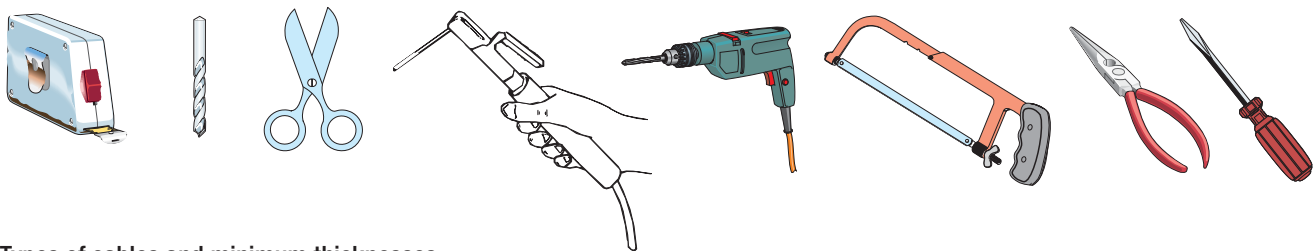

Types of cables and minimum thicknesses

Connection	Cable type	Cable length 1 < 15 m	Cable length 15 < 30 m
Control panel power supply 230 V	H05RN-F	3G x 1,5 mm ²	3G x 2,5 mm ²
Motor power supply 230 V		4G x 1,5 mm ²	4G x 2,5 mm ²
Flashing light		2 x 0,5 mm ²	2 x 1,5 mm ²
Photocell transmitters	FROR CEI	2 x 0.5 mm ²	
Photocell receivers	20-22	4 x 0.5 mm ²	
Control and safety devices	IEC EN 50267-2-1	2 x 0.5 mm ²	
Encoder	TWISTED	max 30 m	
Antenna	RG58	max 10 m	

N.B. : If the cables differ in length from what shown in the table, the cable cross-section is determined according to the actual current draw of the devices connected and according to the provisions of the IEC EN 60204-1 standard.

For connections that require several, sequential loads, the sizes given on the table must be re-evaluated based on actual power draw and distances. When connecting products that are not specified in this manual, please refer to the documentation provided with said products.

INSTALLATION

△ The following illustrations are only examples, given that the space for securing the operator and accessories varies depending on the overall dimensions. The installation technician is responsible for choosing the most suitable solution.

📖 The following drawings refer to a standard installation of an inward opening gate.

Laying the corrugated pipes and inspection chambers

Make the hole for the box.

Prepare the junction boxes and corrugated pipes necessary for connection to the inspection chamber and the drain pipe.

📖 The number of tubes depends on the type of system installed and any accessories.

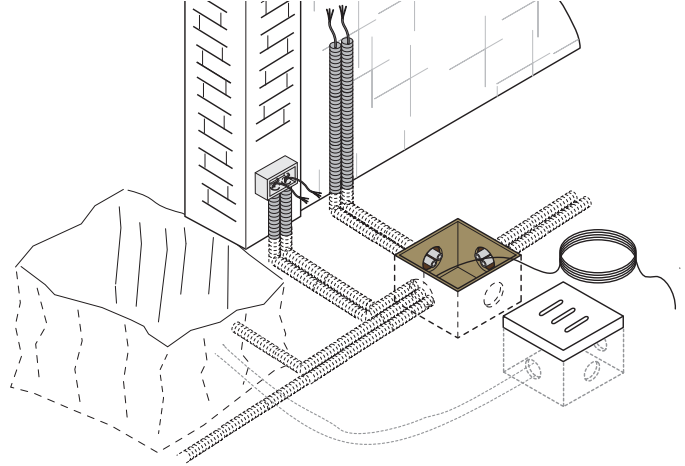
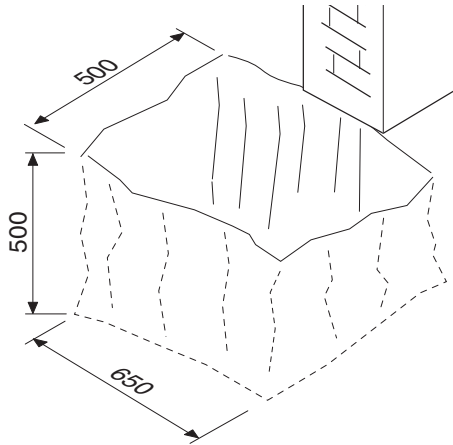

Installing the foundation box

Lean the box against the pillar making sure that the corrugated pipes and the drain pipe pass through the designated holes. Fill the hole with concrete.

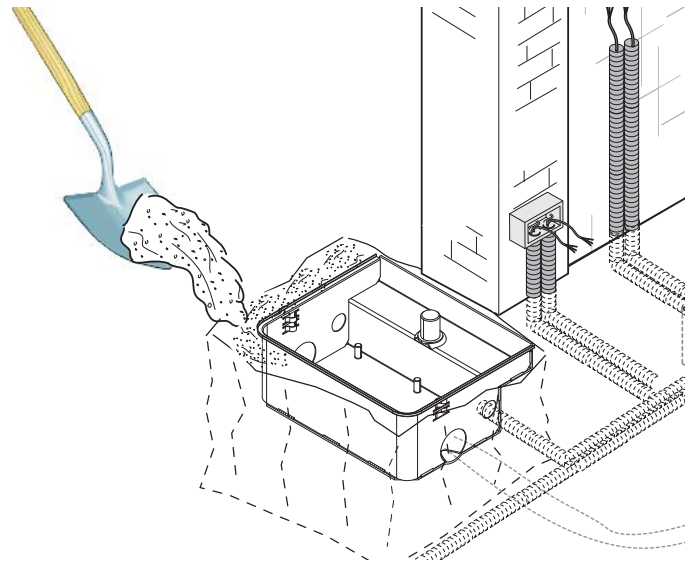
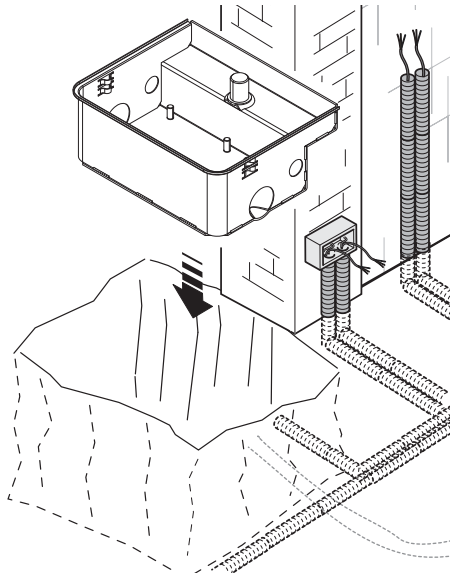

Position the box level with the ground and place the pin in line with the upper gate hinge. Wait at least 24h to cure. Clean any remaining concrete from inside the box.

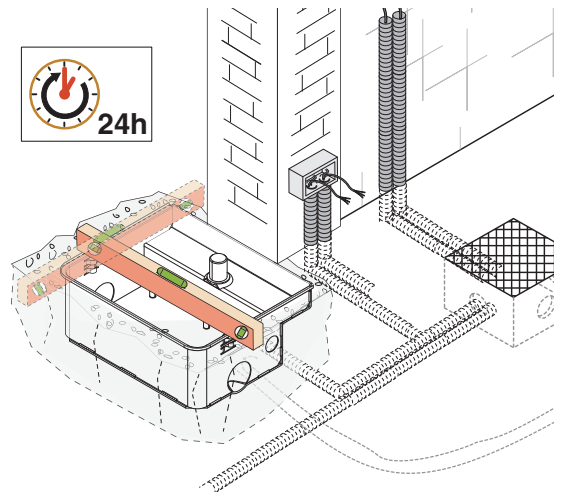
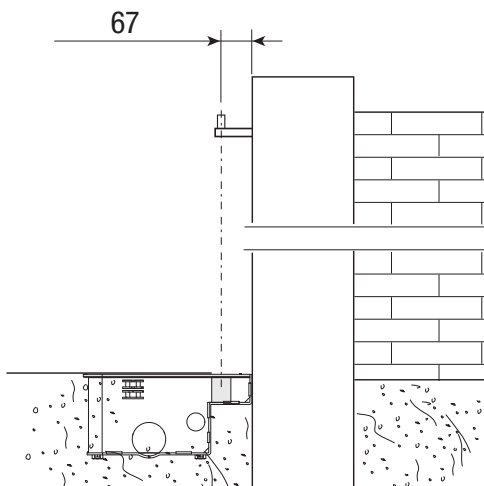

Lubricate the foundation case pin, the latch and the gate bracket pin.

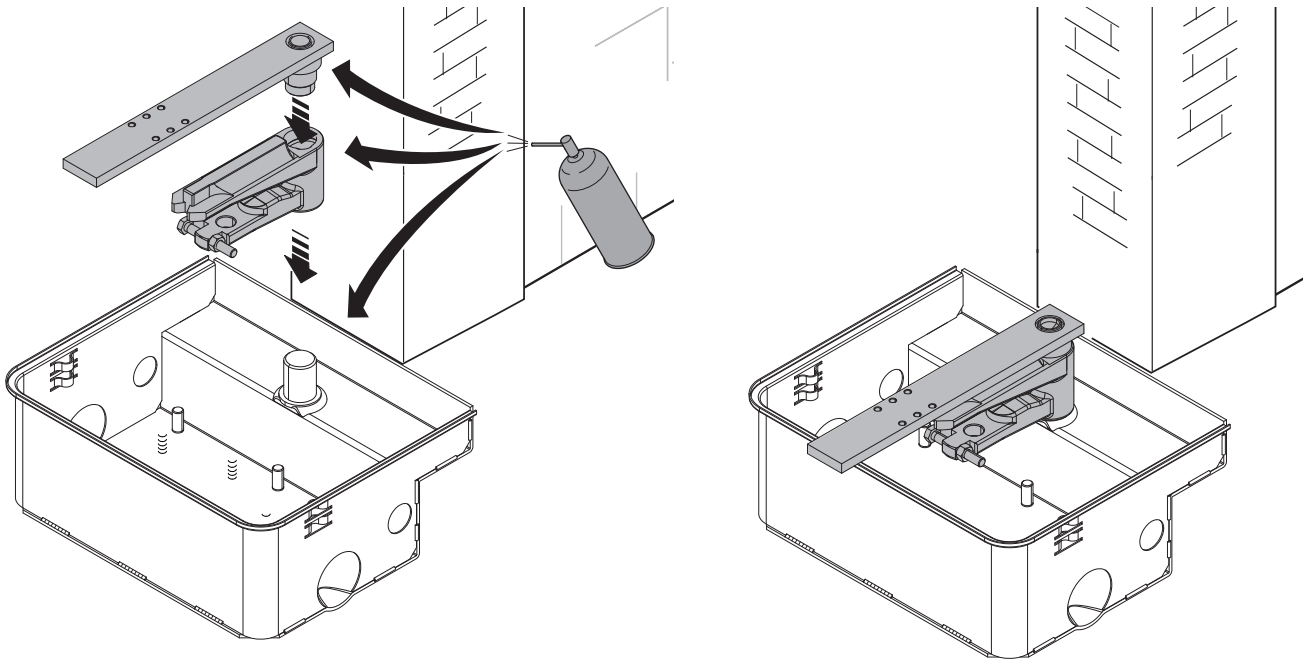

Install the gate leaf, inserting the upper hinge.
Check that the leaf opens and closes without difficulty.
Carefully fix or weld the door to the gate fixing bracket.

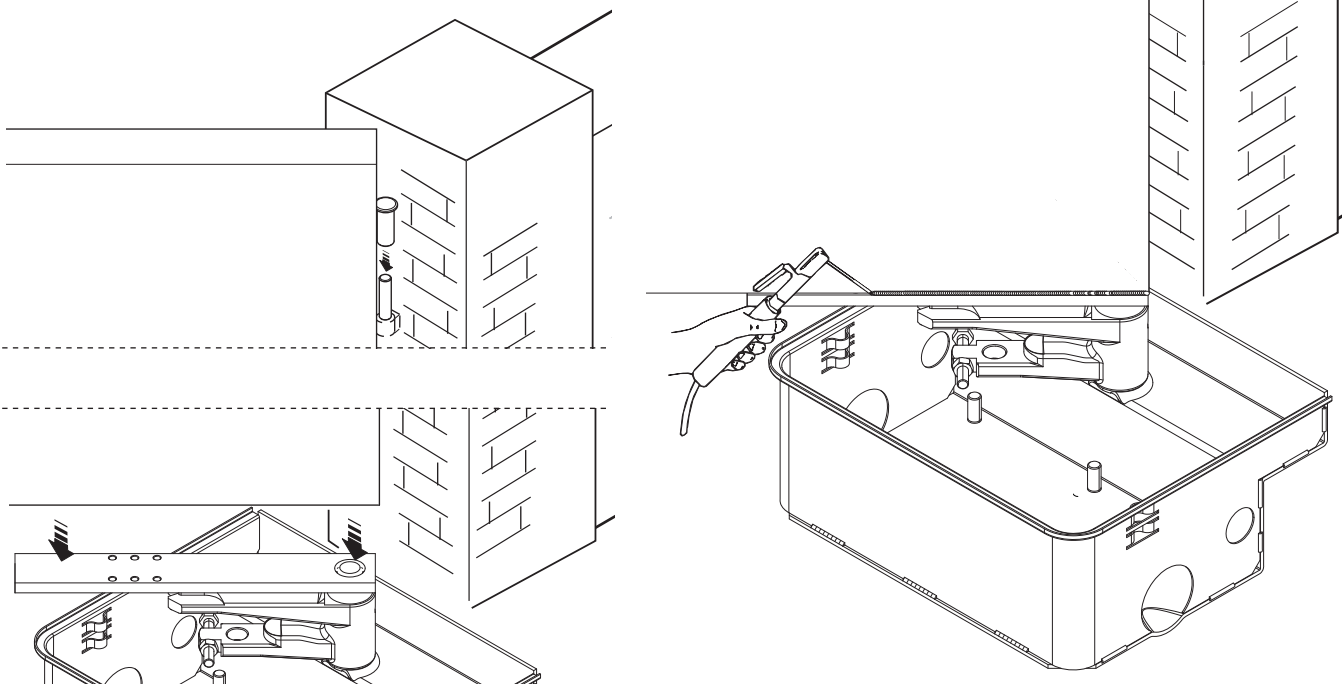

Securing the release

It is important to lubricate the release tab; follow the instructions in the manual of the device selected for information on installation and operation.

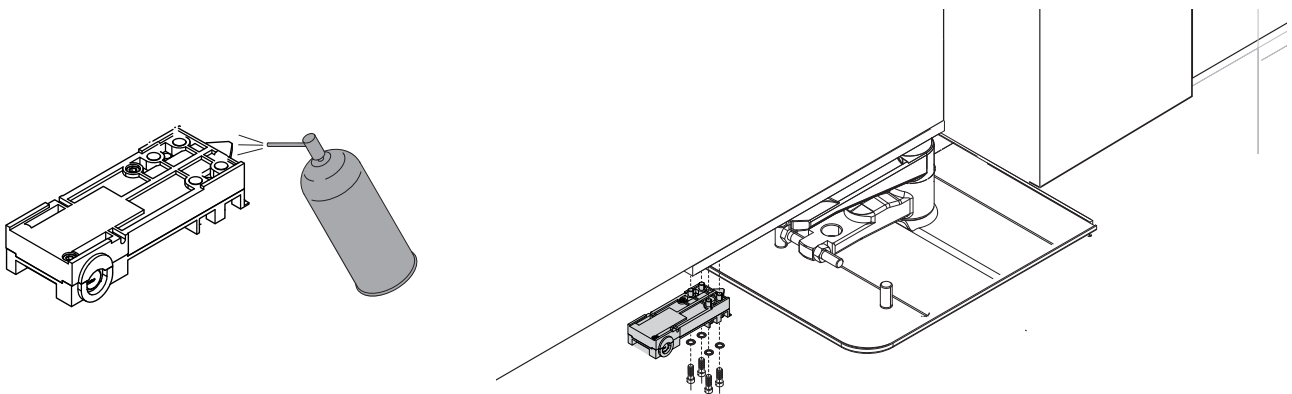

Fastening the gearmotor

Fit the (a) adjusting bolt into the gearmotor. The direction in which to insert the bolt depends on the operator's position.

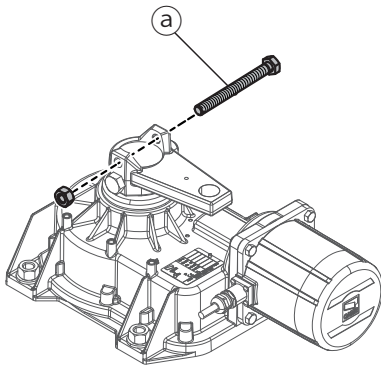

LEFT SIDE

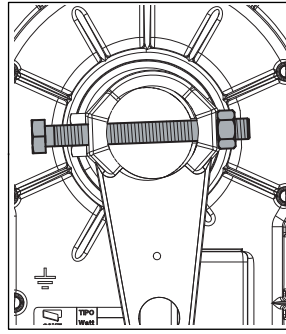

RIGHT SIDE

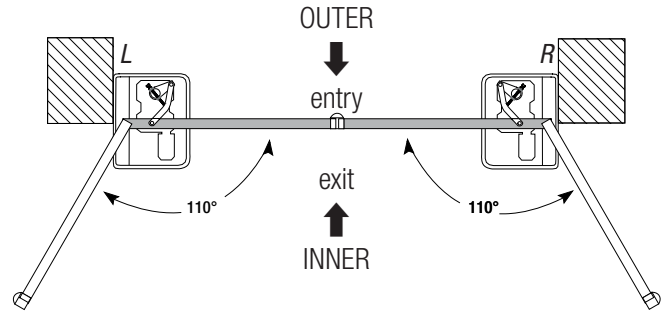
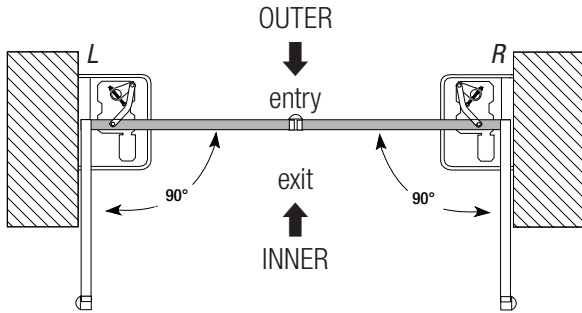
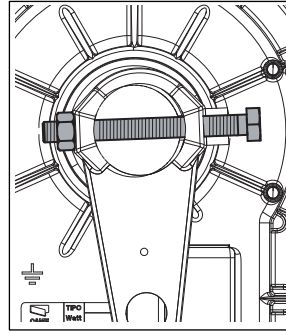

Open the leaf to simplify gearmotor installation and securing inside the foundation case. Use studs and nuts (supplied).

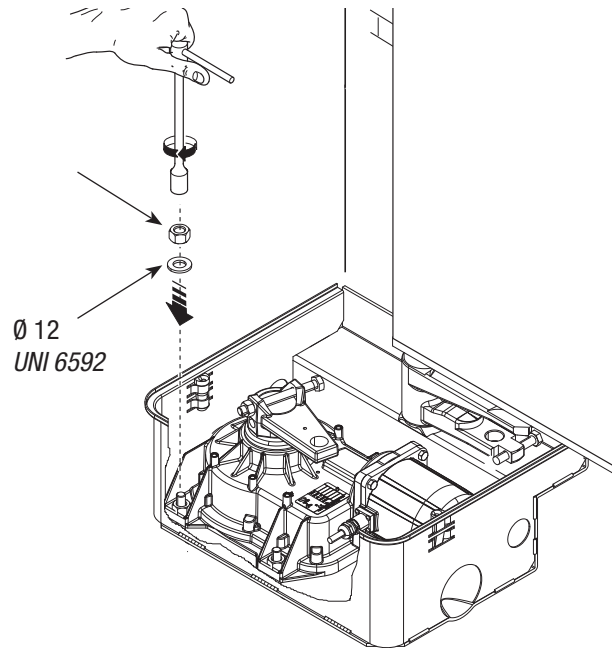
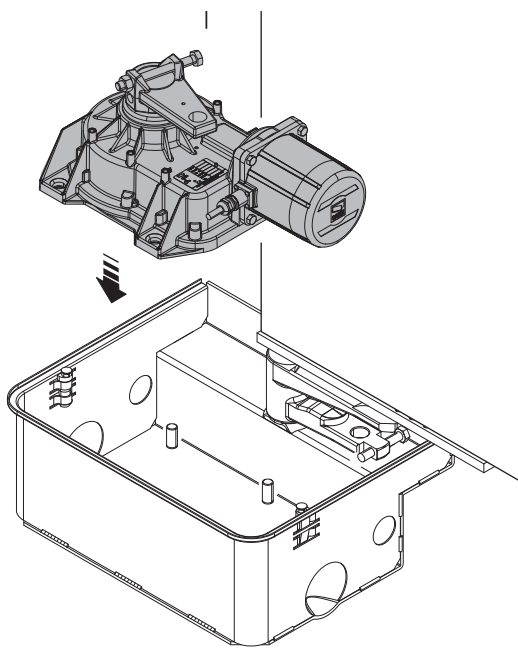

Lubricate the transmission lever and push it into the holes of the gearmotor arm and case lever.

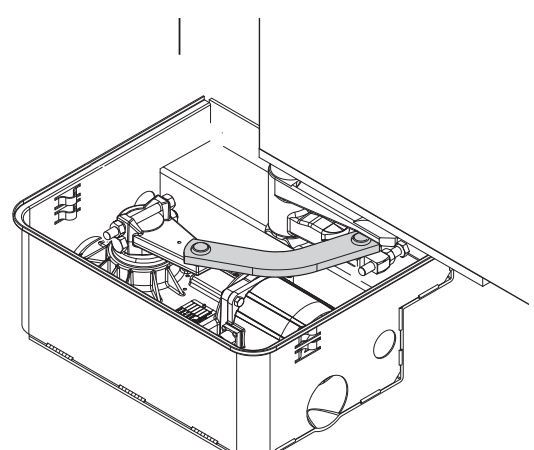
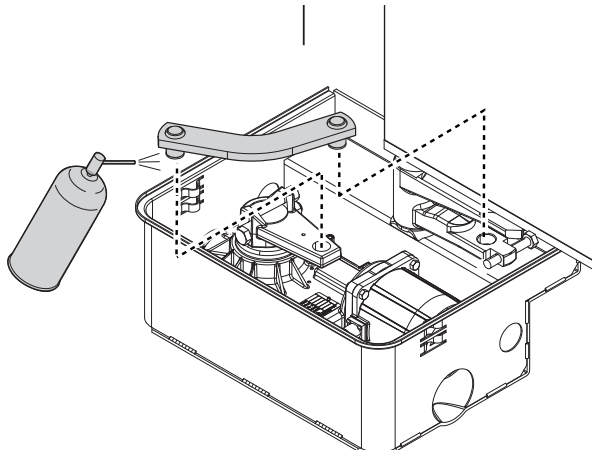

Determining the end run points

During opening:

- open the leaves completely (the maximum aperture is 110 °);
- loosen the screw (1) until it makes contact with the case (3);
- tighten the nut (2) to lock the screw into position.

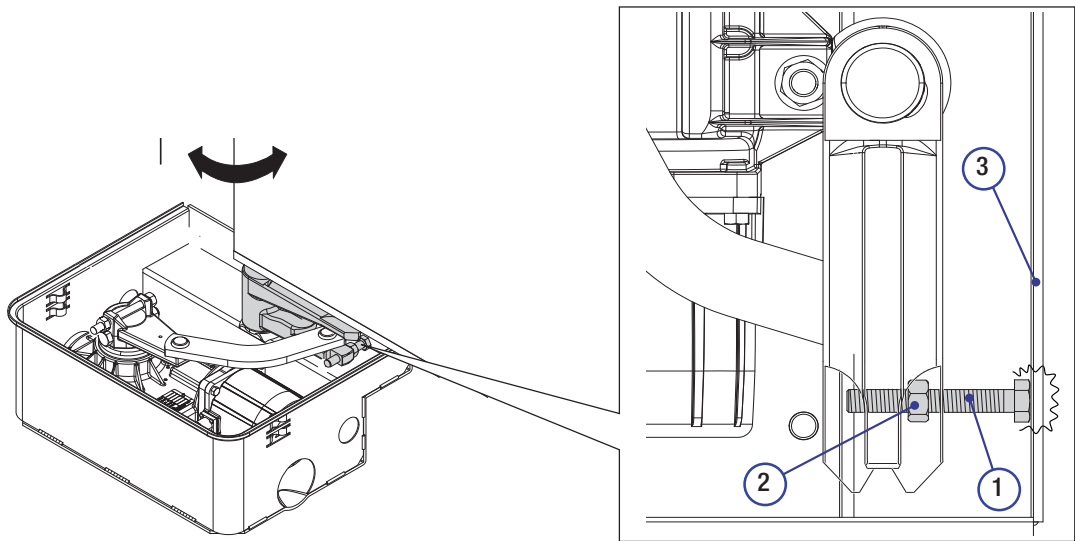

During closing:

- close the leaves completely;
- loosen the adjusting screw (1) until it makes contact with the transmission lever (2);
- tighten the nut (3) to lock the screw into position.

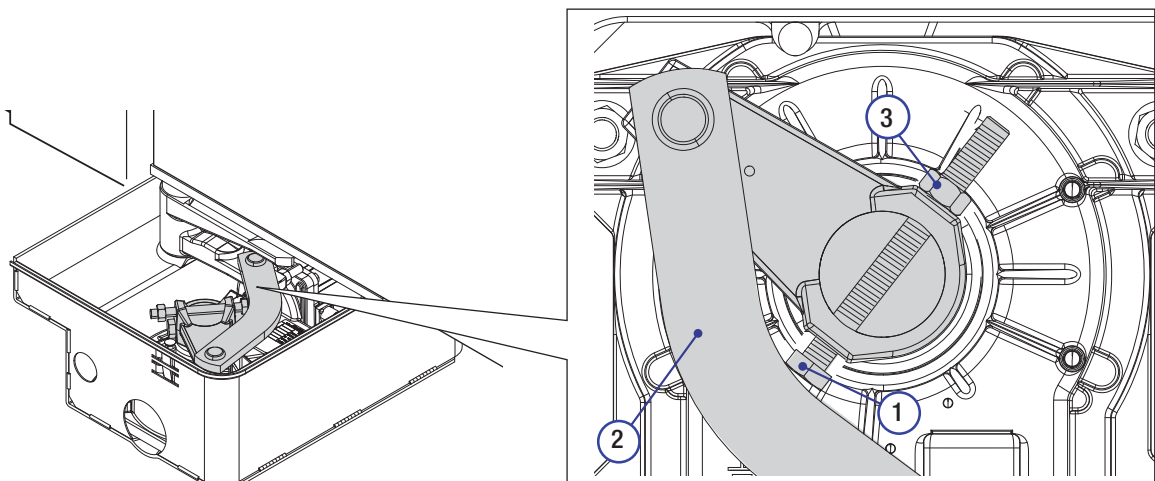

Electrical connections

⚠ For electrical connection operations follow the information in the control panel technical documents.

Gearmotor	Control panel
FROG-A	ZA3N - ZM3E
FROG-AV	ZA3N - ZM3E
FROG-AE	ZM3E

M1 - 230 V AC delayed-opening gearmotor.

M2 - 230 V AC delayed-closing gearmotor

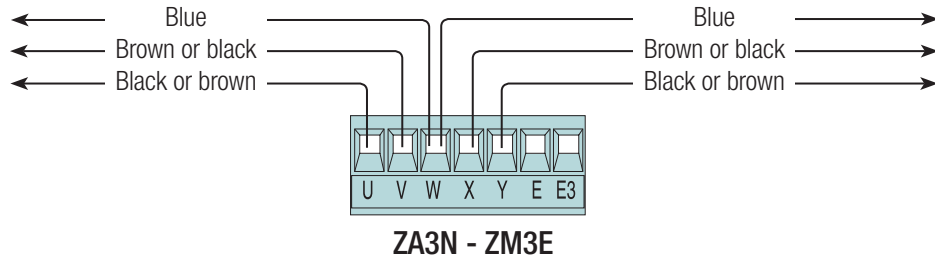
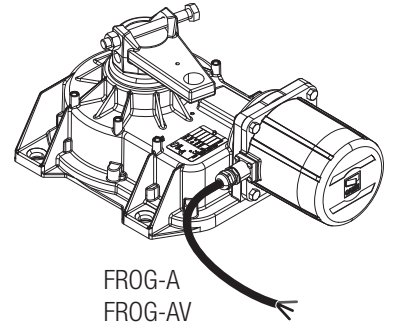
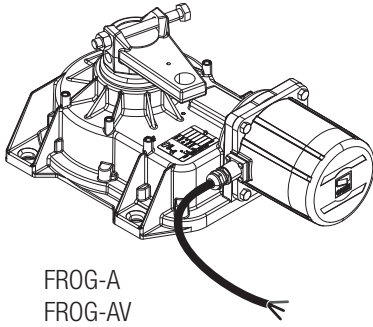

☞ If the gate fails to open after an opening command, invert cables U-V and X-Y.

Connecting the encoder-fitted gearmotors to the control panel

M1 - 230 V AC delayed-opening gearmotor.

M2- 230 V AC delayed-closing gearmotor.

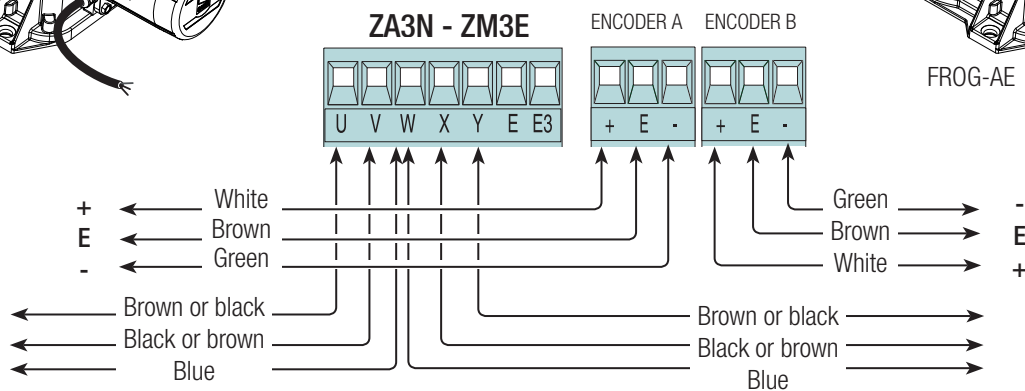
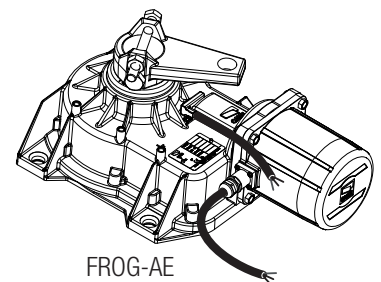
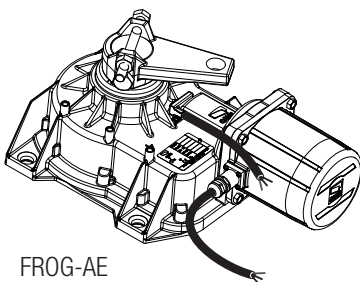

FINAL OPERATIONS

Securing the cover

Rest the cover on the foundation case and fix it with the screws (supplied).

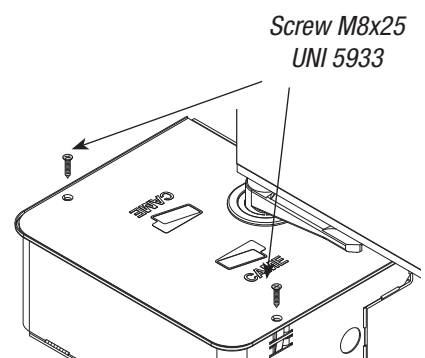
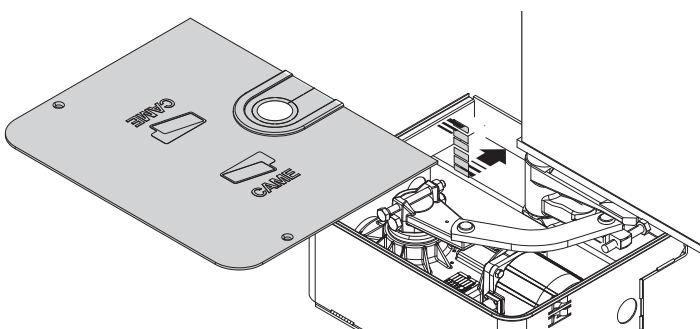

Leaf manual release

Insert the key/lever into the release lock and turn it counter-clockwise. Open the leaf until reaching end run

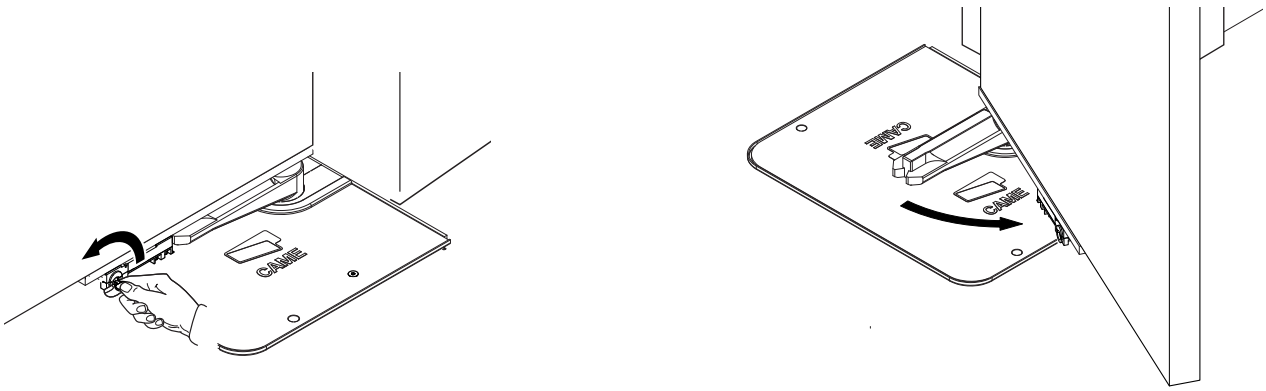

To relock the door, return it to its closed position.

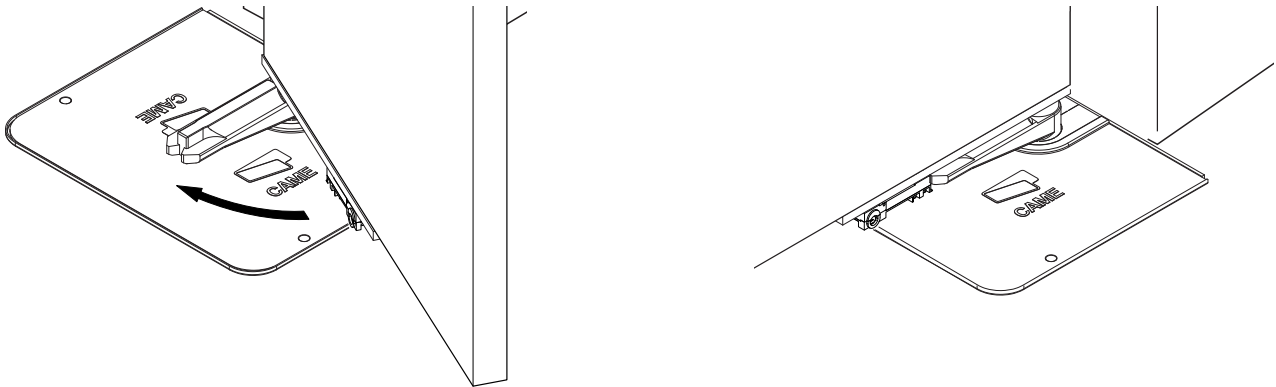

INSTALLING AND CONNECTIONS FOR OUTWARD-OPENINGS

Below are the only procedures that vary compared to standard installations:

Fastening the gearmotor

Fit the **a** adjusting bolt into the gearmotor. The direction in which to insert the bolt depends on the operator's position.

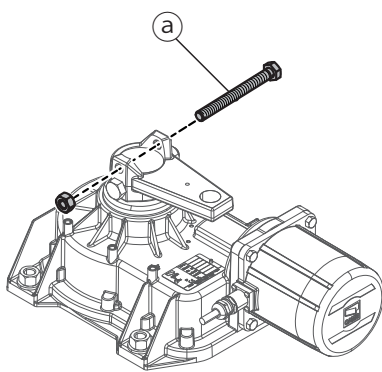

LEFT SIDE

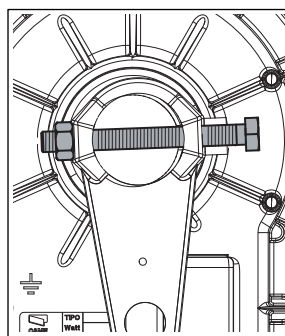

RIGHT SIDE

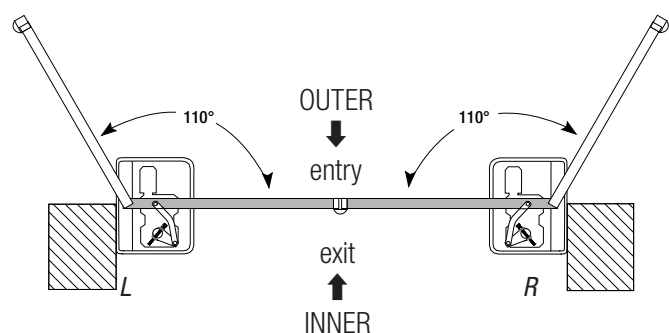
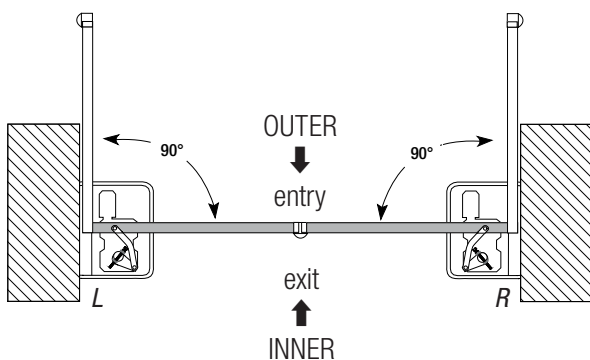
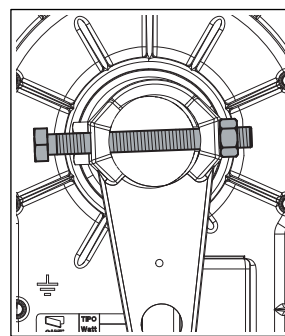

Extraordinary maintenance

- △ The table below is used to note any extraordinary maintenance, repairs or improvements carried out by specialist companies.
 △ Extraordinary maintenance must be carried out by specialist technicians.

Extraordinary maintenance log

Installation technician stamp	Operator name
	Date of intervention
	Technician signature
	Customer signature
Intervention carried out _____ _____ _____ _____	

Installation technician stamp	Operator name
	Date of intervention
	Technician signature
	Customer signature
Intervention carried out _____ _____ _____ _____	

Installation technician stamp	Operator name
	Date of intervention
	Technician signature
	Customer signature
Intervention carried out _____ _____ _____ _____	

Installation technician stamp	Operator name
	Date of intervention
	Technician signature
	Customer signature
Intervention carried out _____ _____ _____ _____	

TROUBLESHOOTING

MALFUNCTIONS	POSSIBLE CAUSES	CHECKS AND REMEDIES
The gate does not open or close	<ul style="list-style-type: none"> No power supply The gearmotor is unlocked The transmitter battery is flat The transmitter is broken The stop button is stuck or broken. The opening/closing button or the key selector switch are stuck 	<ul style="list-style-type: none"> Check for mains power Lock the gearmotor Replace the batteries Contact service Contact service Contact service
The gate opens but does not close	<ul style="list-style-type: none"> The photocells are engaged 	<ul style="list-style-type: none"> Make sure that the photocells are clean and work correctly Contact service

DISMANTLING AND DISPOSAL

☞ CAME S.p.A. implements an EN ISO 14001-certified and compliant Environmental Management System at its plants, to ensure environmental protection. Please continue our efforts to protect the environment, something that CAME considers to be one of the foundations in developing its business and market strategies, simply by observing brief recommendations as regards disposal:

♻️ DISPOSAL OF PACKAGING

Packaging components (cardboard, plastic, etc.) can be disposed of together with normal household waste without any difficulty, by simply separating the different types of waste and recycling them.

Before proceeding, it is always advisable to check specific regulations in force in the place of installation.

DISPOSE OF PROPERLY!

♻️ DISPOSAL OF THE PRODUCT

Our products are made with different materials. Most of them (aluminium, plastic, iron, electrical cables) can be disposed of together with normal household waste. They can be recycled if collected, sorted and sent to authorised centres.

Other components (control boards, transmitter batteries, etc.), on the other hand, may contain pollutants.

They should therefore be removed and handed over to companies authorised to recover and recycle them.

Before proceeding, it is always advisable to check specific regulations in force in the place of disposal.

DISPOSE OF PROPERLY!

DECLARATION OF CONFORMITY

Declaration CE - - CAME S.p.A. declares that this device complies with the essential requirements and other relevant provisions established in 2006/42/CE e 2004/108/CE.

Request and original copy.

English - Manual code: **119AS45EN** ver. **7** 02/2016 © CAME S.p.A.
The data and information provided in this manual are subject to change at any time without prior notice by CAME S.p.A.

CAME
safety & comfort



Came S.p.A.

Via Martiri Della Libertà, 15

31030 **Dosson di Casier**
Treviso - Italy

📞 (+39) 0422 4940

📠 (+39) 0422 4941

Via Cornia, 1/b - 1/c

33079 **Sesto al Reghena**
Pordenone - Italy

📞 (+39) 0434 698111

📠 (+39) 0434 698434

www.came.com