

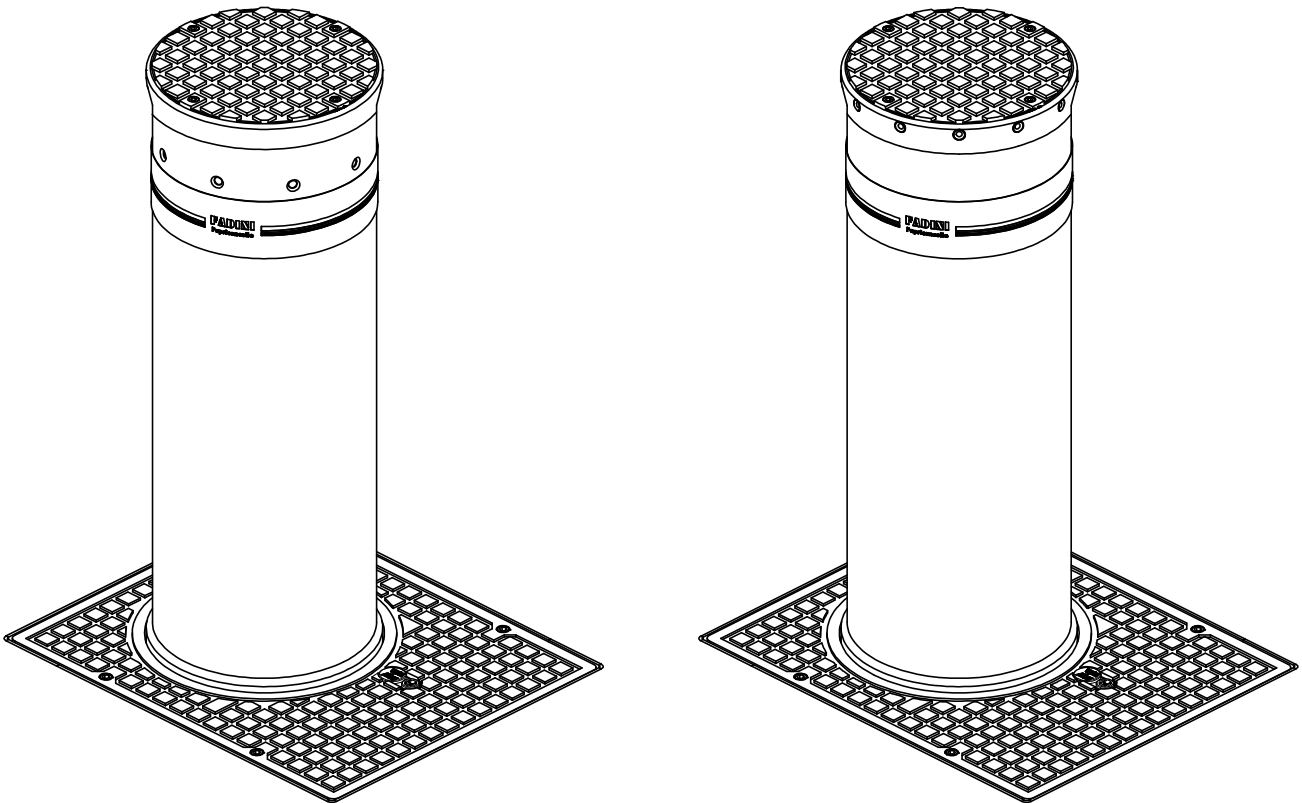

TALOS



**BOLLARD WITH RETRACTABLE CYLINDRICAL POST
OIL-HYDRAULICALLY OPERATED**



EN 13241
EN 12453
EN 12445

Made in Italy

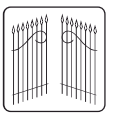

FADINI
the gate opener

GENERAL WARNINGS FOR PEOPLE SAFETY**THANK YOU**

Thank you for purchasing a Fadini product. Please read these instructions carefully before using this appliance. The instructions contain important information which will help you get the best out of the appliance and ensure safe and proper installation, use and maintenance. Keep this manual in a convenient place so that you can always refer to it for the safe and proper use of the appliance.

INTRODUCTION

This operator is designed for a specific scope of applications as indicated in this manual, including safety, control and signaling accessories as minimum required with Fadini equipment. □ Any applications not explicitly included in this manual may cause operation problems or damages to properties and people. □ Meccanica Fadini snc is not liable for damages caused by the incorrect use of the equipment, or for applications not included in this manual or for malfunctioning resulting from the use of materials or accessories not recommended by the manufacturer. □ The manufacturer reserves the right to make changes to its products without prior notice. □ All that is not explicitly indicated in this manual is to be considered not allowed.

BEFORE INSTALLATION

Before commencing operator installation assess the suitability of the access, its general condition and the structure. □ To check that the ground is stable, to avoid subsequent settling or deformation in the traffic control post installation area. □ Make sure that there is no risk of impact, crushing, shearing, conveying, cutting, entangling and lifting situations, which may prejudice people safety. □ Do not install near any source of heat and avoid contacts with flammable substances. □ Keep all the accessories able to turn on the operator (transmitters, proximity readers, key-switches, etc) out of the reach of the children. □ Transit through the access only with stationary operator. □ Do not allow children and/or people to stand in the proximity of a working operator. □ To ensure safety in the whole movement area of a bollard it is advisable to install photocells, sensitive edges, magnetic loops and detectors. □ Use yellow-black strips or proper signals to identify dangerous spots. □ Before cleaning and maintenance operations, disconnect the appliance from the mains by switching off the master switch. □ If removing the actuator, do not cut the electric wires, but disconnect them from the terminal box by loosening the screws inside the junction box.

INSTALLATION

All installation operations must be performed by a qualified technician, in observance of the Machinery Directive 2006/42/CE and safety regulations EN 12453 - EN 12445. □ Verify the presence of a thermal-magnetic circuit breaker 0,03 A - 230 V - 50 Hz upstream the installation. □ Use appropriate objects to test the correct functionality of the safety accessories, such as photocells, sensitive edges, etc. □ Carry out a risk analysis by means of appropriate instruments measuring the crushing and impact force of the main opening and closing edge in compliance with EN 12445. □ Identify the appropriate solution necessary to eliminate and reduce such risks.

□ In case where the gate to automate is equipped with a pedestrian entrance, it is appropriate to prepare the system in such a way to prohibit the operation of the engine when the pedestrian entrance is used. □ Apply safety nameplates with CE marking on the gate warning about the presence of an automated installation. □ The installer must inform and instruct the end user about the proper use of the system by releasing him a technical dossier, including: layout and components of the installation, risk analysis, verification of safety accessories, verification of impact forces and reporting of residual risks.

INFORMATION FOR END-USERS

The end-user is required to read carefully and to receive information concerning only the operation of the installation so that he becomes himself responsible for the correct use of it. □ The end-user shall establish a written maintenance contract with the installer/maintenance technician (on -call). □ Any maintenance operation must be done by qualified technicians. □ Keep these instructions carefully.

WARNINGS FOR THE CORRECT OPERATION OF THE INSTALLATION

For optimum performance of system over time according to safety regulations, it is necessary to perform proper maintenance and monitoring of the entire installation: the automation, the electronic equipment and the cables connected to these. □ The entire installation must be carried out by qualified technical personnel, filling in the Maintenance Manual indicated in the Safety Regulation Book (to be requested or downloaded from the site www.fadini.net/supporto/downloads). □ Operator: maintenance inspection at least every 6 months, while for the electronic equipment and safety systems an inspection at least once every month is required. □ The manufacturer, Meccanica Fadini snc, is not responsible for non-observance of good installation practice and incorrect maintenance of the installation.

DISPOSAL OF MATERIALS

Dispose properly of the packaging materials such as cardboard, nylon, polystyrene etc. through specializing companies (after verification of the regulations in force at the place of installation in the field of waste disposal). Disposal of electrical and electronic materials: to remove and dispose through specializing companies, as per Directive 2012/19/UE. Disposal of substances hazardous for the environment is prohibited.



GENERAL DESCRIPTION OF THE PRODUCT

Talos is a bollard fitted with a fully retractable post sinking flat to the ground level. It is an oil-hydraulic system, the movements of which are by an incorporated motor-pump. It is designed to securely stop traffic from an area.

The TALOS series includes a vast selection of options as indicated below, varying in height, thickness and depth of embedding (constraint) for impact resistance (the abbreviation HRC identifies those bollards having higher ratings of resistance to crash and impact than the standard versions).

The construction features and installation procedure are the same across the entire range:

model	post thickness (mm)	stroke (mm)	crash resistance (J)	model	post thickness (mm)	stroke (mm)	crash resistance (J)
TALOS 9450	4	500	320.000	TALOS 9651	12	500	450.000
TALOS 9450/HRC	4	500	420.000	TALOS 9651/HRC	12	500	550.000
TALOS 9460	4	600	320.000	TALOS 9661	12	600	450.000
TALOS 9460/HRC	4	600	420.000	TALOS 9661/HRC	12	600	550.000
TALOS 9470	4	700	320.000	TALOS 9671	12	700	450.000
TALOS 9470/HRC	4	700	420.000	TALOS 9671/HRC	12	700	550.000
TALOS 9480	4	800	320.000	TALOS 9681	12	800	450.000
TALOS 9480/HRC	4	800	420.000	TALOS 9681/HRC	12	800	550.000

The retractable post, 275 mm diameter, is made of S235JRH steel (4 mm thickness) and S355JRH steel (12 mm thickness), cathodization treated and polyester powder coating.

A stainless steel version is available, INOX Aisi 304 satin finish, but only in the 4 mm thickness option.

In the HRC options, the post (raised) stays embedded into the casing 40 cm (constraint) deeper rather than 20 cm as with the standard versions, thus ensuring higher resistance to impact and crash.

The electronic controller Elpro S40 is to be installed externally, in a sheltered place.

A wide range of safety and control accessories make this bollard easy and safe to operate and therefore suitable to any applications, either in public or private areas.

Any TALOS can be completed with supplementary accessories, to be specified at the time of the order as required (pre-assembled and pre-wired to the internal terminal block):

- **Solenoid valve:** it allows the post to lower in case of power failure.
- **Presence sensor (pressure switch):** it prevents the post from rising in case an obstacle stays on it.
- **Beeper:** an acoustic device operating during the rising and lowering movements of the post.
- **Heating resistor:** a device used to keep Talos warm inside when the external environment is below 5 °C.

VERSION WITH LEDs FITTED ONTO THE COVER-RUBBER EDGE ASSEMBLY

As from week 28/2019 it will be available the TALOS in the version with Nos. 12 led lights fitted onto the cover-rubber edge assembly of the rising cylinder head.

This version replaces the correspondent model with Nos. 9 led lights in the top of the rising cylinder.

This technical improvement will not affect in any way the performance or the functional features of the bollard.

For a correct installation always refer to all the indications and figures shown in this installation manual.

DECLARATION OF CONFORMITY:

Meccanica Fadini snc (Via Mantova, 177/A - 37053 Cerea - VR - Italy) declares under its own responsibility that TALOS is in compliance with the Directive 2006/42/EC on machinery, moreover: is to be sold and installed as a comprehensive "Automatic System", including the accessories and components as recommended by the Manufacturing Company. In observance of the current directives, any automation is to be regarded as a "machine". Therefore it is required that all the applicable safety norms are strictly complied with by installation agents, who are also required to issue a Declaration of Conformity. The manufacturing company is not liable for incorrect applications or misuse of its products that are declared to be produced in compliance with the following norms: Analysis of the risk and actions to cure them EN 12445 & EN 12453, Low Voltage Directive 2014/35/UE, Electro-magnetic Compatibility Directive 2014/30/UE. In order to certify the product the Manufacturer declares under his own responsibility the compliance with the PRODUCT regulations under the NORMS EN 13241-1.

Meccanica Fadini s.n.c.
Responsible Manager

MAIN COMPONENTS

English

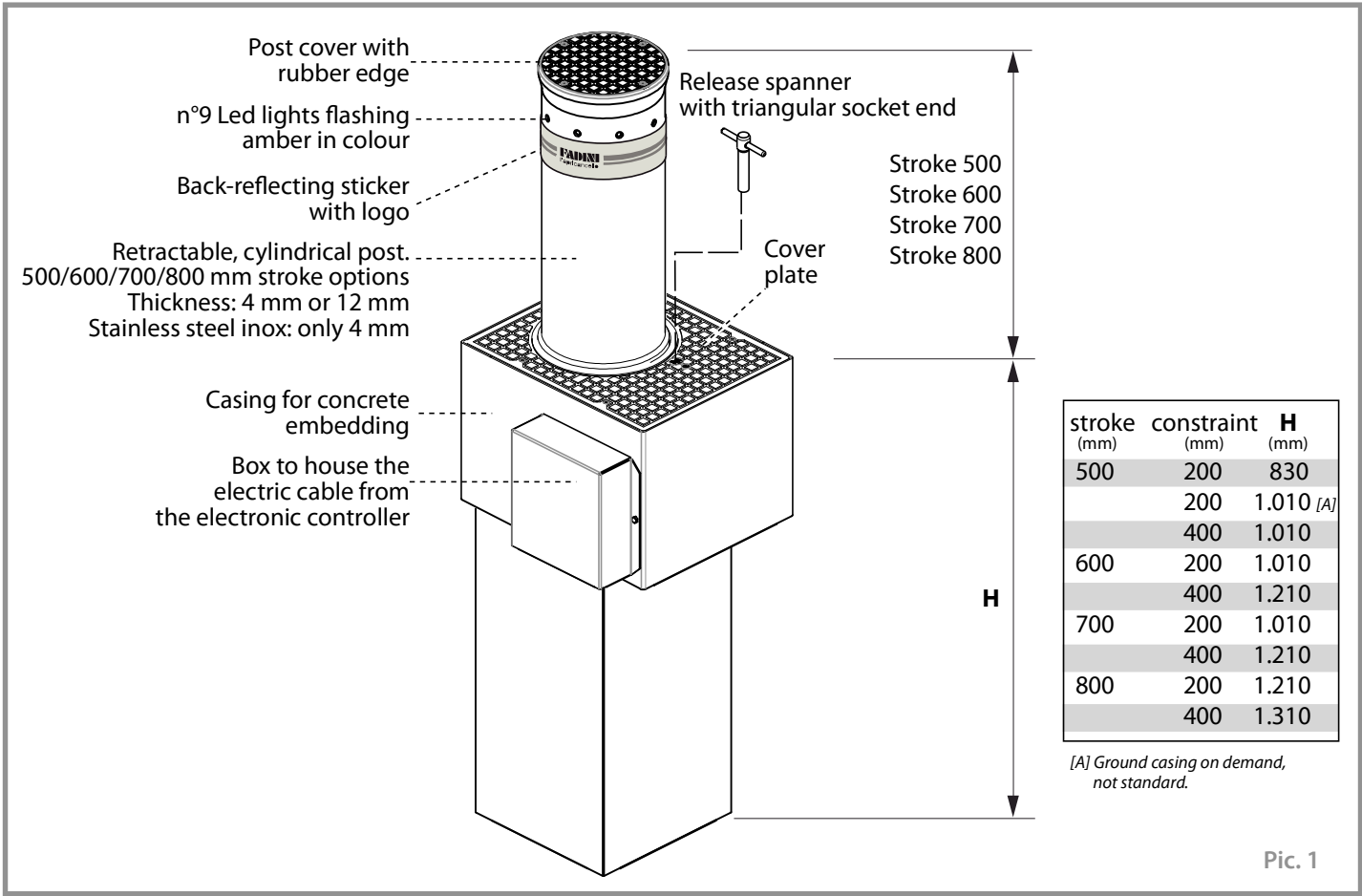

Pic. 1

NON MANDATORY FUNCTIONING TEST (not required for installation purposes)

The Talos bollard is factory-tested in any normal working conditions before being sent out to customers.

Anyway, to enable some functioning tests to be carried out before installation, it is possible to access the inner terminal block for the electrical connections by removing the hatch cover: undo the two lateral screws of the cover and pull outwards the junction box including the connector.



NOTE WELL: once test is finished, put the box and the hatch cover back.

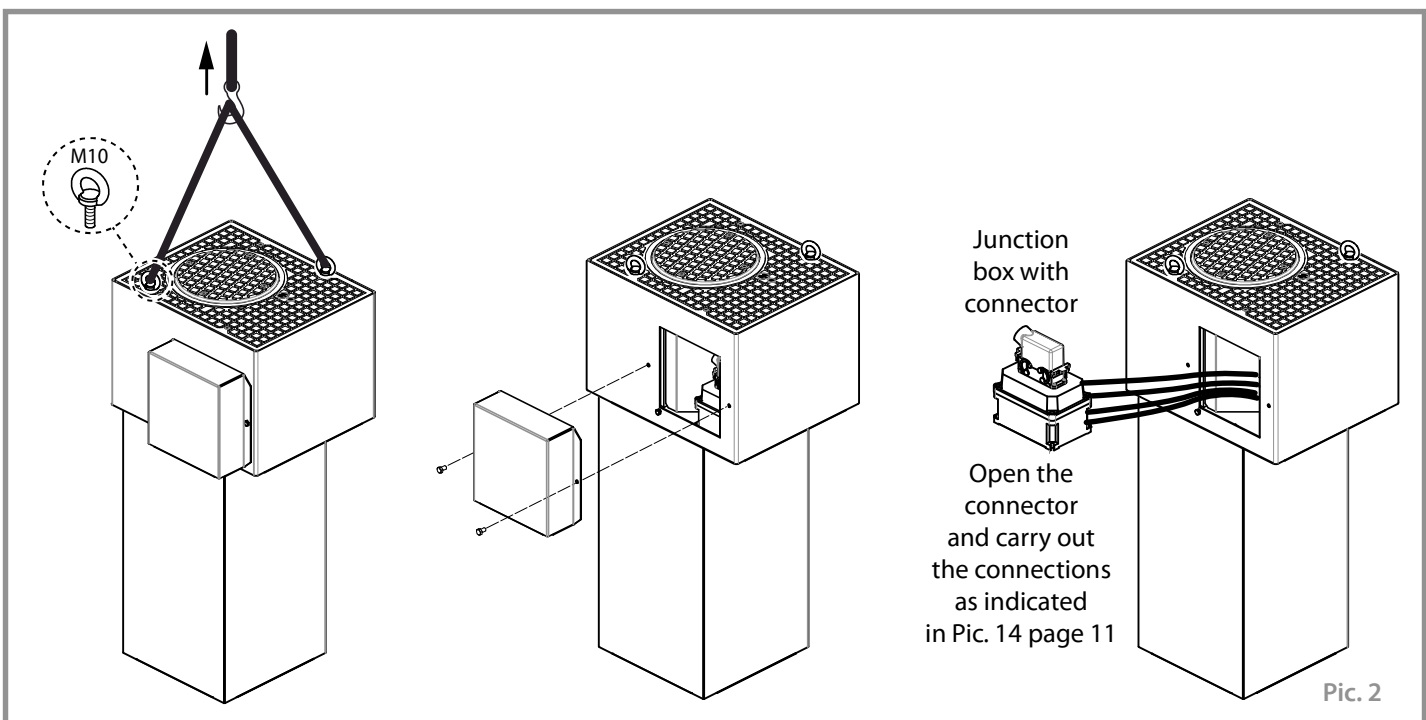

Pic. 2

COMPONENTS FOR A COMPLETE INSTALLATION

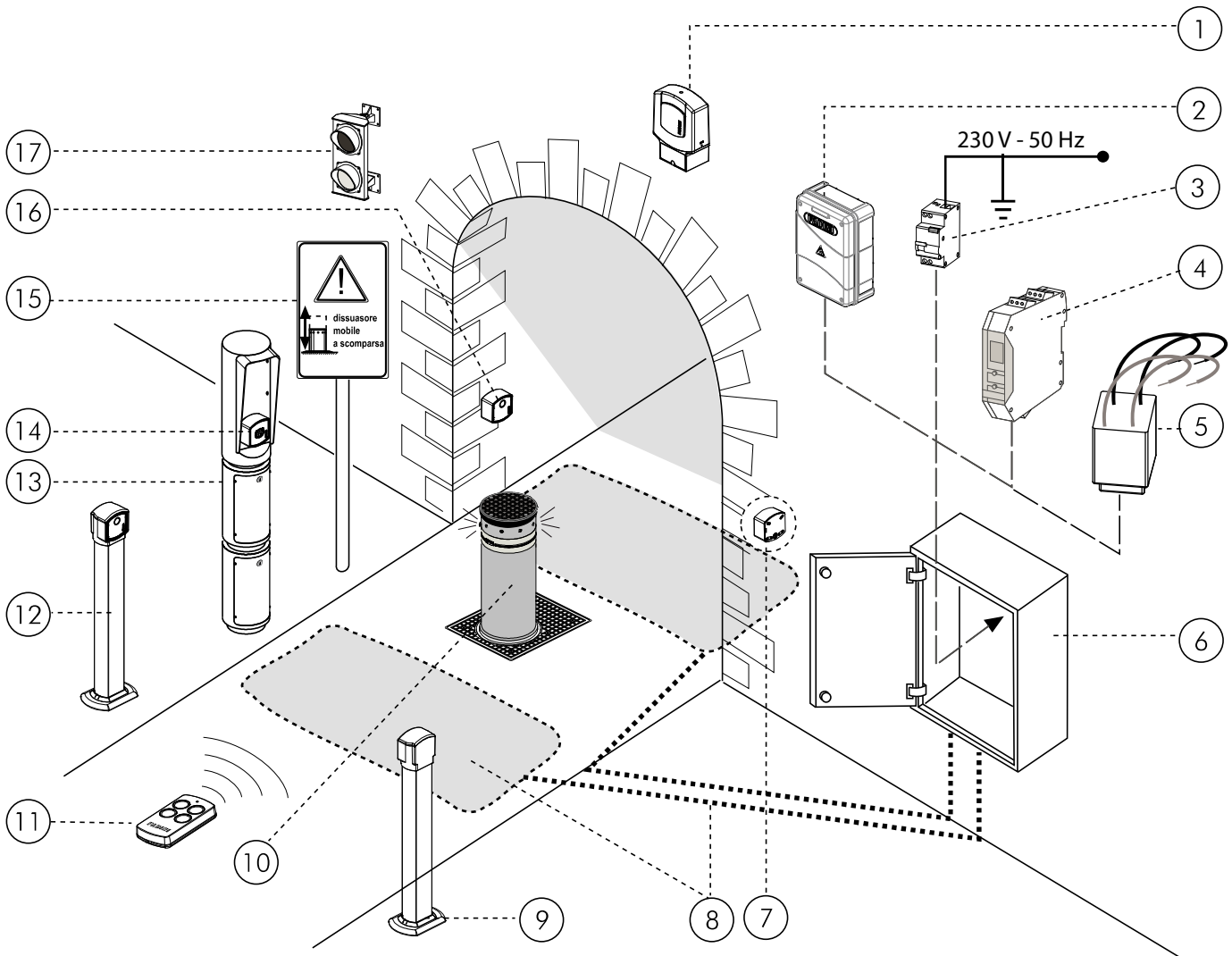

List of all the possible accessories for system operations and safety (see general catalogue).
General indicative diagram:

- 1 - Led flasher
- 2 - Electronic controller with radio receiver
- 3 - 0,03 A magnetic thermal circuit breaker (not in the catalogue)
- 4 - Loop detector for metallic masses, two channels
- 5 - Voltage stabilizer for single coil application (Talos with solenoid valve)
- 6 - Burglar-proof enclosure
- 7 - Photocell receiver, recess mount
- 8 - Pre-assembled loop with power supply cable
- 9 - Post for photocell projector
- 10 - Oil-hydraulic bollard Talos series
- 11 - Remote control transmitter
- 12 - Post for photocell receiver
- 13 - Post to take command accessories
- 14 - Key-switch
- 15 - Warning signal bollard in motion
- 16 - Photocell projector, recess mount
- 17 - Double head traffic lights



Make sure that the electric cables of all the accessories are led to the electronic controller Elpro S40 without interfering with any other utility. Depth and diameter of the cable ducts are to comply with the principles of the good installation technique and the safety rules in force on the place of the application.

Pic. 3

REMOVE THE BOLLARD FROM ITS CASING

English

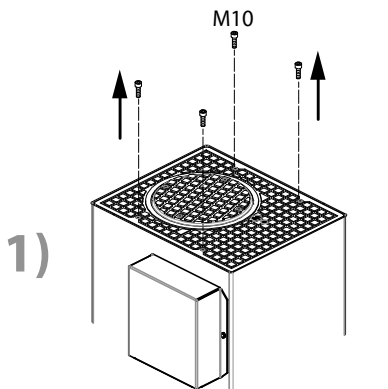

1)

Remove the M10 screws on the squared cover plate

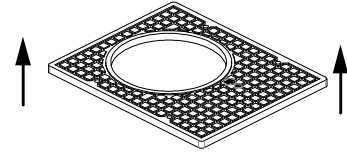

2)

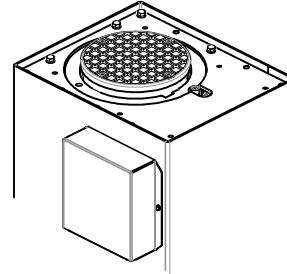

3)

Remove the inner fixing plate

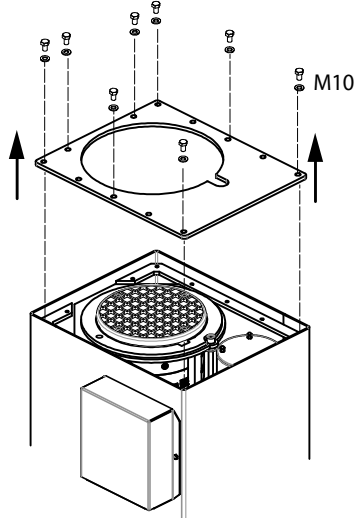

4)

Screw the two lifting rings down into the pre-holed seats

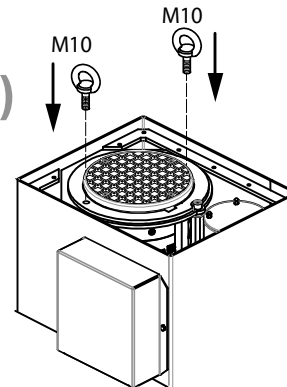

5)

NOTE WELL: make sure the ground cable is disconnected from the casing before lifting

! Carefully hoist and remove the inner assembly of the bollard by a winch. Make sure the cables are not torn or cut or the inner hydraulic pipes are damaged in this phase.

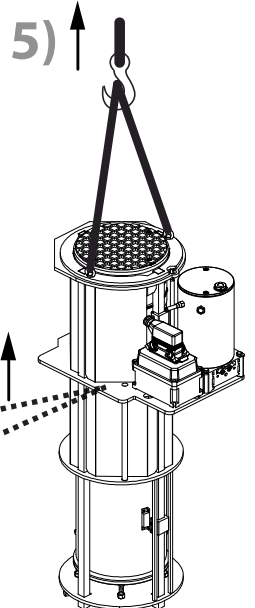
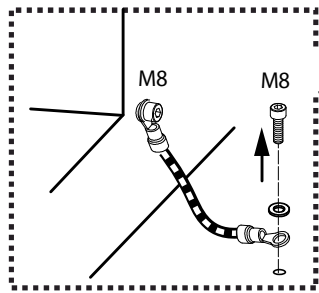

Casing to set into a concrete foundation

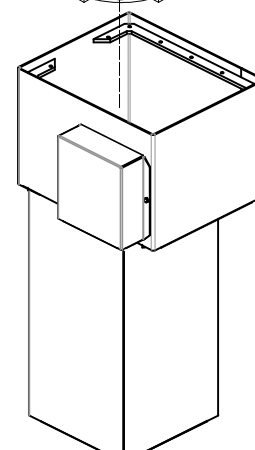

Pic. 4

CEMENTING THE CASING

A pit is to be dug into the ground following the dimensions as indicated in Pic. 5.

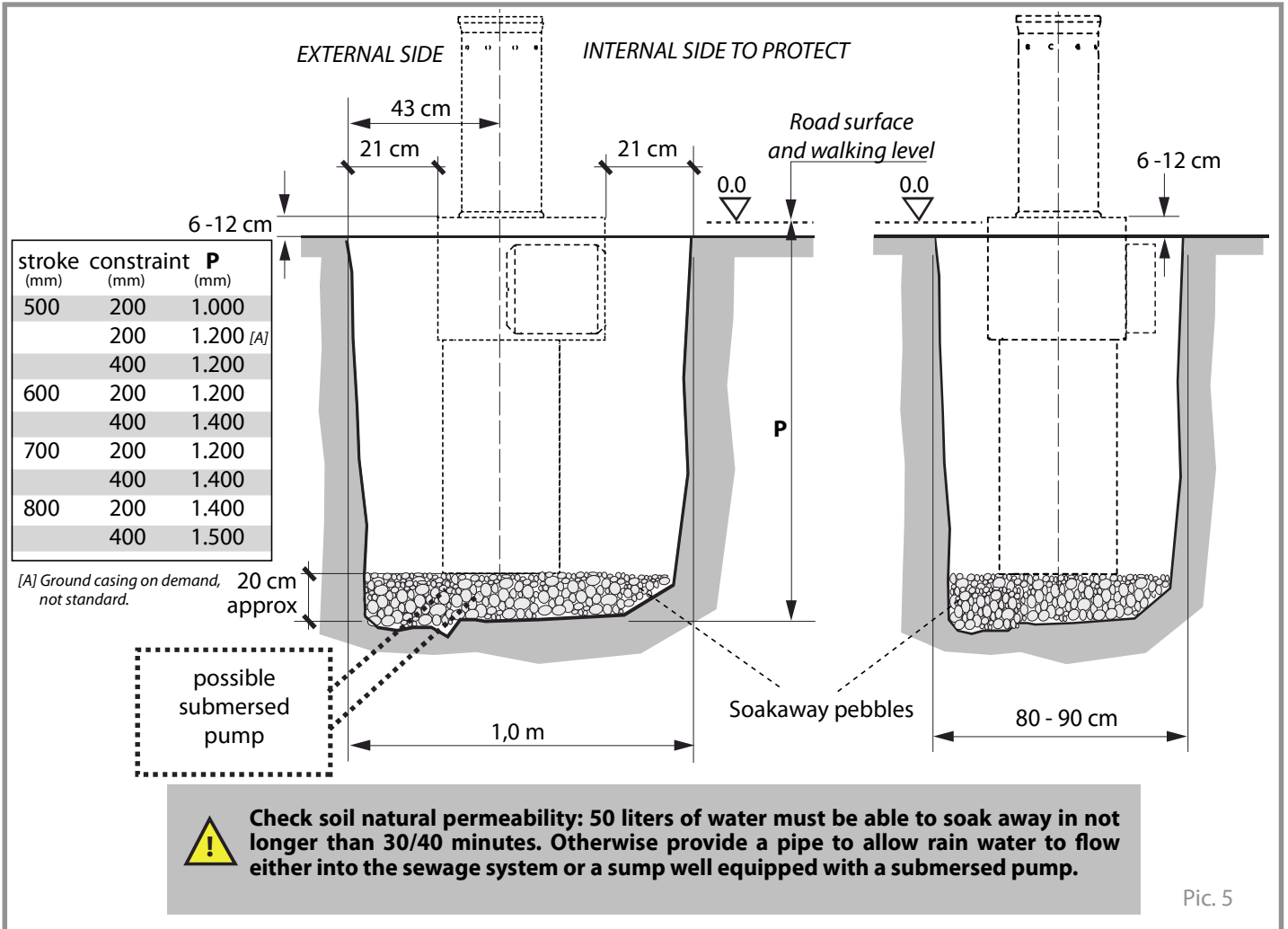

Lay a corrugated tube, Ø 50 mm, to lead the electric cables through it, from a junction box or directly from the electronic controller Elpro S40 (Pic. 6).

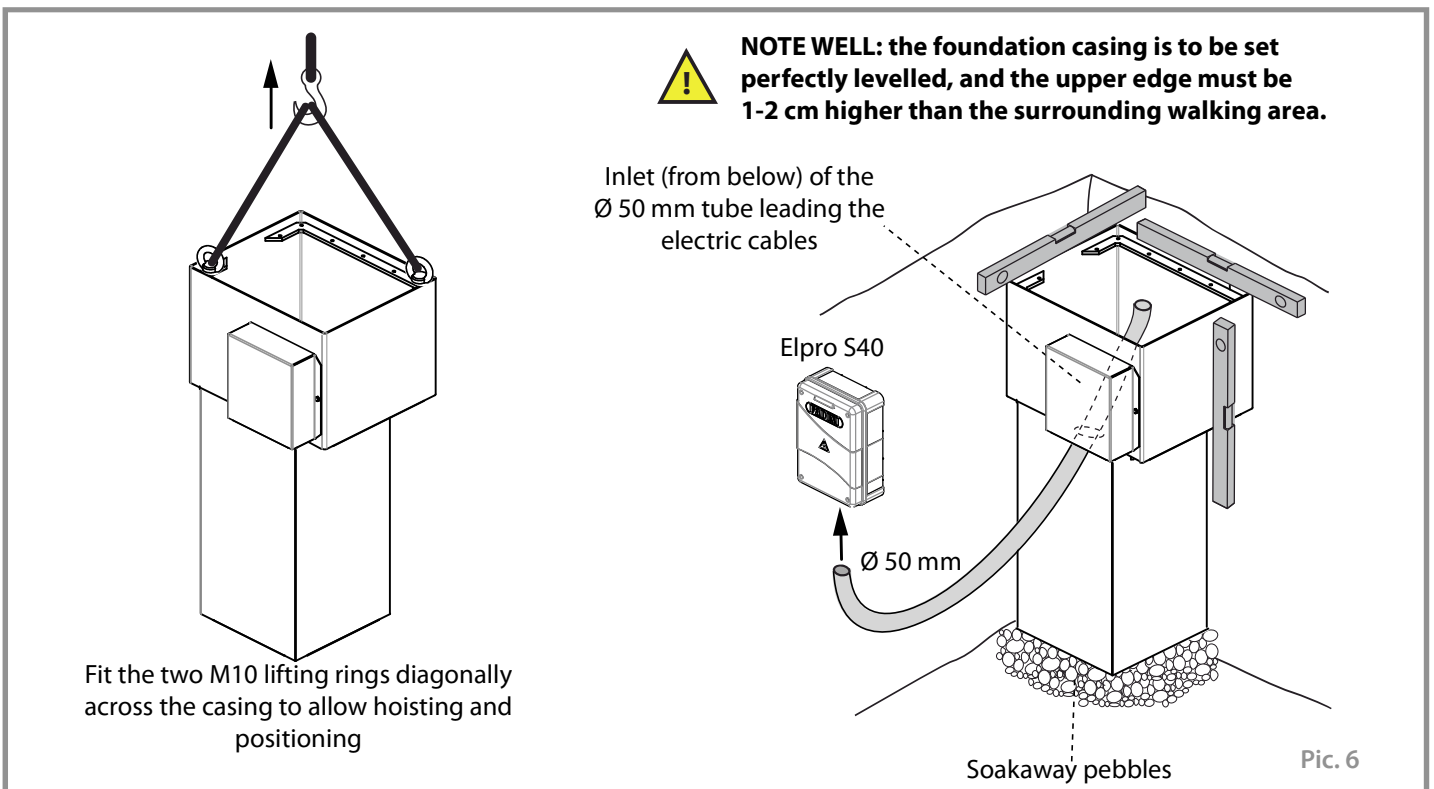

English



The upper level of the foundation casing is to be 1-2 cm higher than the surrounding walking surface, in order to limit the amount of water that may get inside it. Cast concrete all around the casing up to 5-10 cm from walking level. Wait all the time required for concrete to set firmly (at least 7 days) and complete the finishing of the road surface.

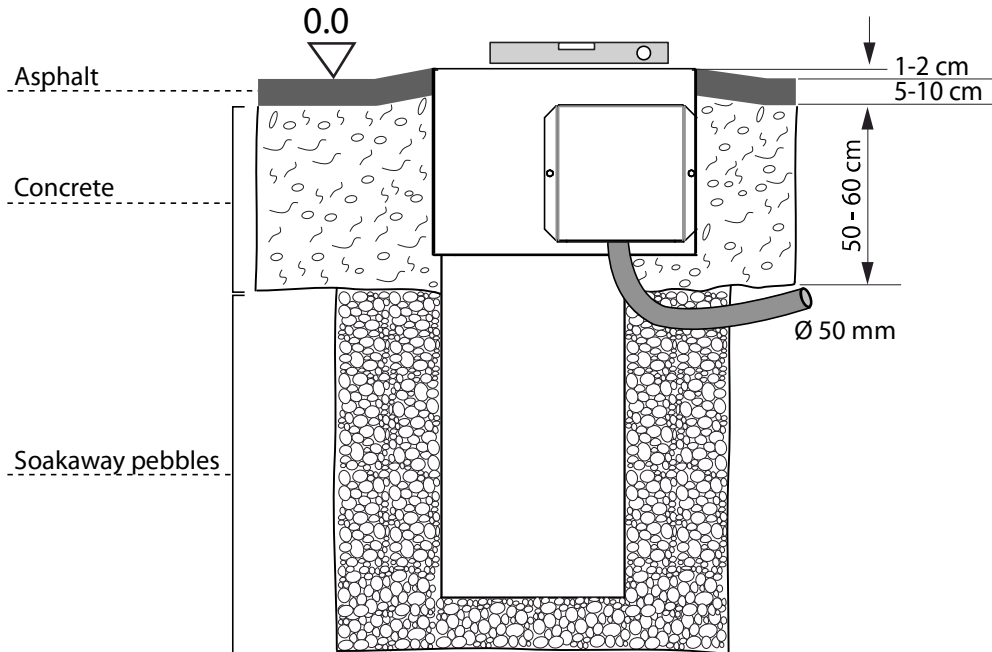

IT IS MOST IMPORTANT THAT THE CASING IS 1-2 cm HIGHER THAN AREA FINISHED LEVEL. IN NO WAY THE TALOS IS TO BECOME A WATER GATHERING BASIN. AVOID AREAS WHERE SOIL TENDS TO SAG TO PREVENT THE BOLLARD FROM BEING FLOODED. IN CASE OF SNOW, THE FLAT SURFACE OF THE COVER PLATE CAN BE EASILY CLEARED EVEN BY HEAVY MECHANICAL MEANS.

Pic. 7

INSTALLING THE BOLLARD

Once concrete has firmly set around the casing, put the inner assembly back into it. Lastly remove the lifting rings.

By a winch put carefully the inner assembly back into the casing, make sure the cables are not torn or cut or the inner hydraulic pipes are damaged in this phase



NOTE WELL: IT IS IMPORTANT THAT THE ENTIRE ASSEMBLY IS PERFECTLY FITTED BACK INTO ITS SEAT. THE PLATE, TO WHICH THE MOTOR-PUMP IS FIXED, MUST FIT WELL ONTO THE INNER SURFACE OF THE CASING. REMOVE POSSIBLE FRAGMENTS.

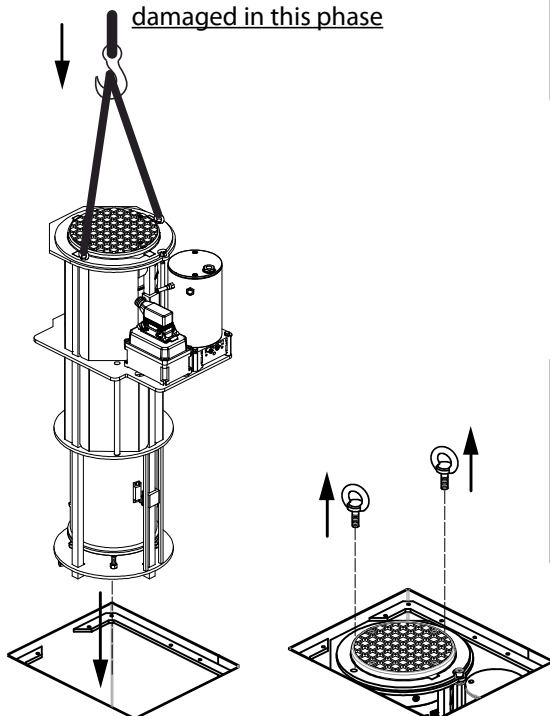

They must be on the same level



They must fit so that the dedicated groove in the casing is fitted perfectly

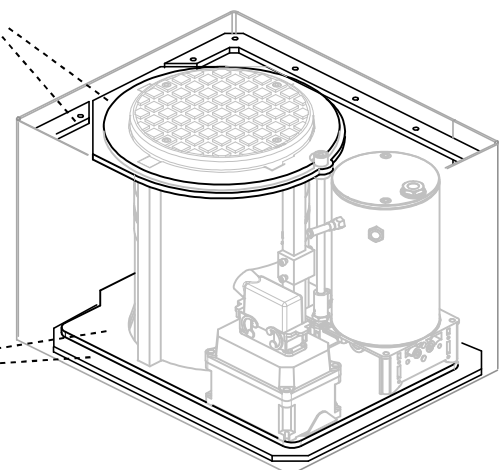

Pic. 8

ARRANGING FOR THE MAGNETIC LOOPS (OPTIONAL)

IMPORTANT: Make sure that the area near and below the ground level where the accessories are installed is clear from electromagnetic sources to prevent interference problems with the detections of the loops and with any other electronic device to control the installation.

The magnetic loop is a safety device, permanently active, to detect vehicles: the bollard is prevented from rising while any vehicle is transiting on the loops.

A hole is to be dug to take the pre-assembled loops that can be provided by the company (see the instructions coming with this item to be informed about all of the possible configurations available).

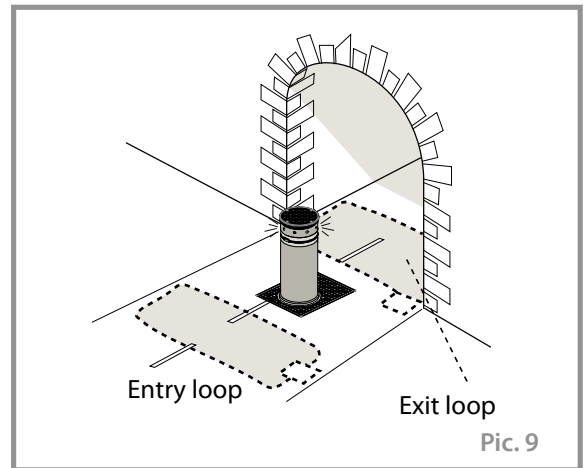

Pic. 9

English

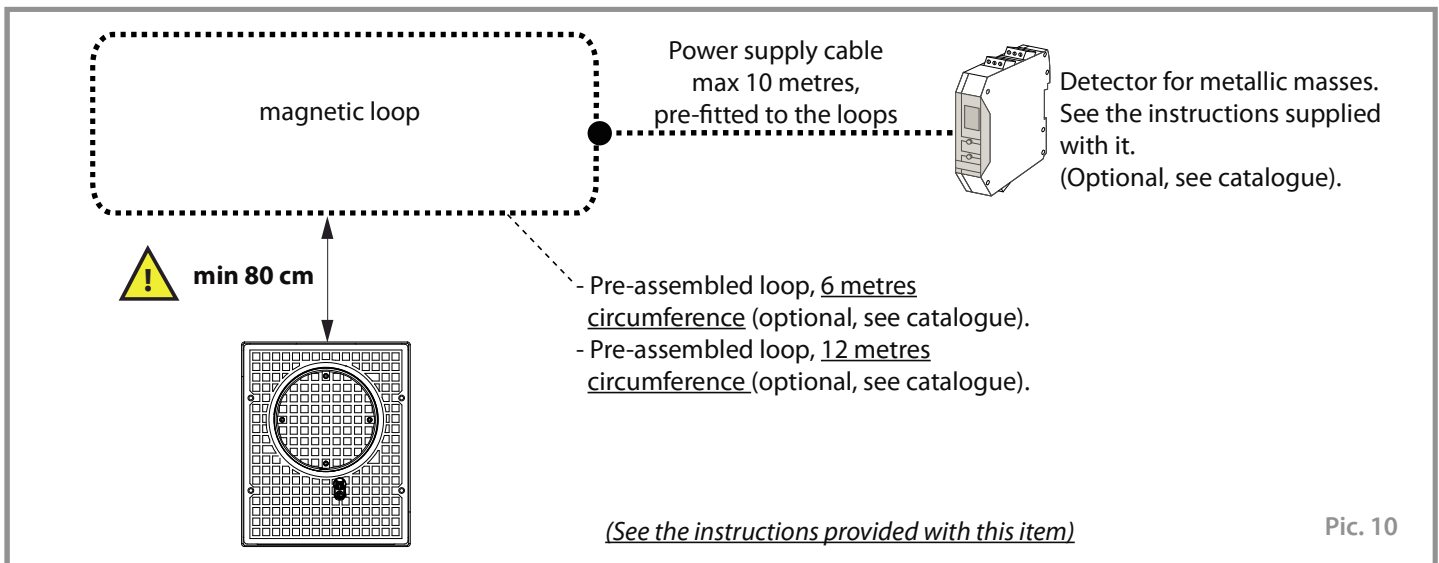

Pic. 10

INSTALLING THE PHOTOCELLS (OPTIONAL ITEM) AND OTHER COMMAND ACCESSORIES AS REQUIRED

The photocells are to be installed at a suitable minimum distance to operate properly as indicated in Pic. 11. Visual 344, with 2 or 3 elements, is a post made of metal designed to provide a support to the electronic controller Elpro S40 in those applications in the open where no other structures are available to this purpose. It is designed to also take any other control accessories, such a key-switch or a video-intercom system, as required near the installation (Pic. 11).

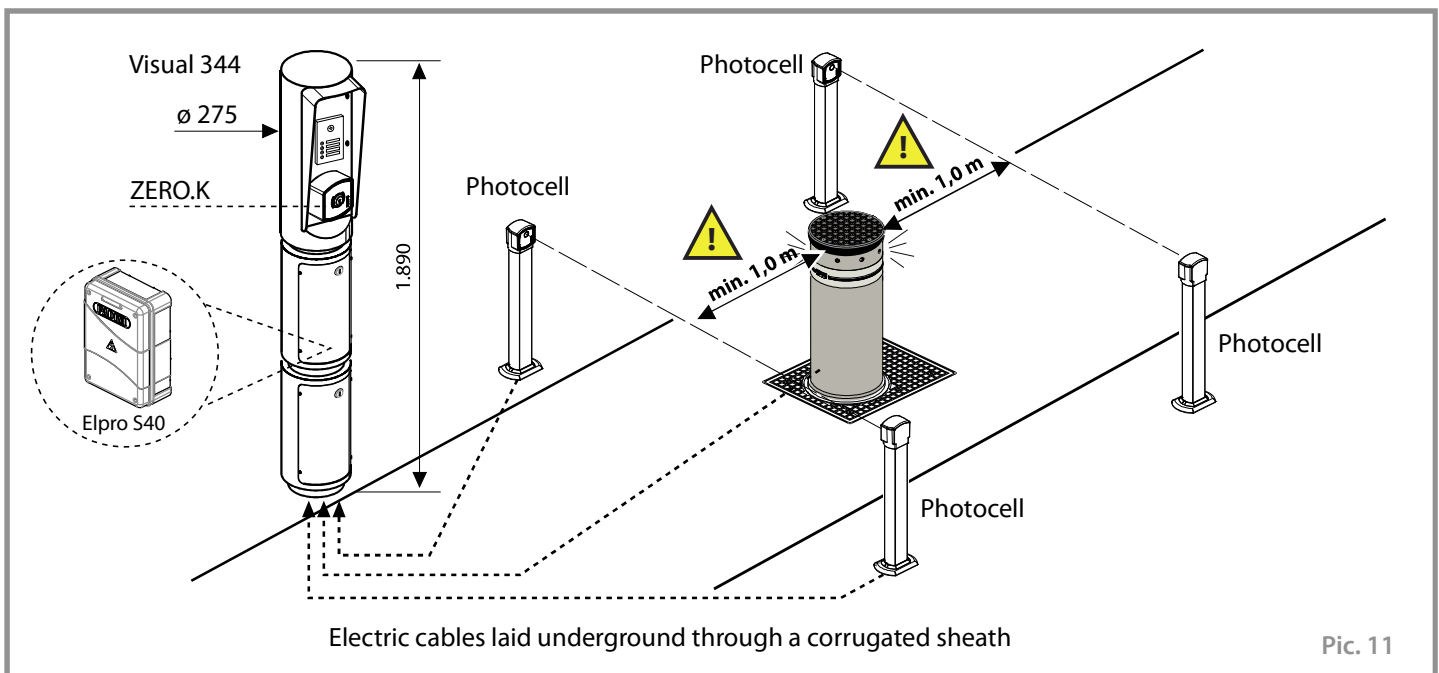

Pic. 11

ELECTRIC CONNECTIONS TO THE ELECTRONIC CONTROLLER ELPRO S40

The electronic controller Elpro S40 is to be installed in a dry and protected place to prevent unauthorized actions. Make sure that all the electric cables of the command and safety accessories are properly led to the controller (Pic.3). Through the previously laid corrugated tube pull a multicore cable, type **BUT FLESSIBILE FG 70R 12x1,5 mm²** (not supplied with the equipment, but available on request as per catalogue) or a multicore cable, type **BUT FLESSIBILE FG 70R 16x1,5 mm²** (not supplied with the equipment, but available on request as per catalogue) for the electrical connections to the Elpro S40 controller, depending on which model of TALOS is required to be installed (see page 18, point 8).

NOTE WELL: Lay a ground cable suitable to the type of installation as required either for public or private users and in compliance with the existing safety norms. A screw is provided for proper connection. For applications in public areas use a cable having a section of 16 mm².

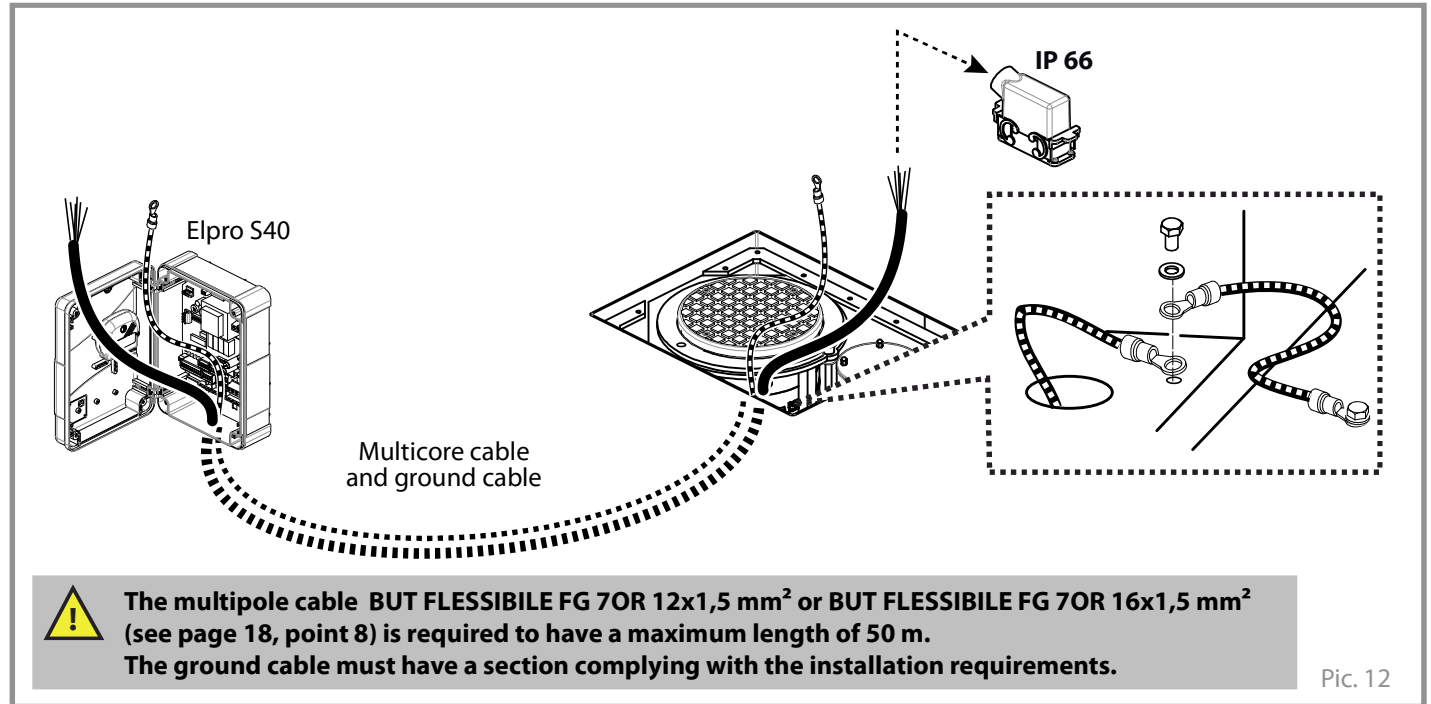

! **ATTENTION:** before carrying on with wiring, it is recommended to identify which optional accessories TALOS is actually fitted with (pressure switch, solenoid valve, beeper or heating resistor), so to arrange the proper connections to the respective terminals in the connector.

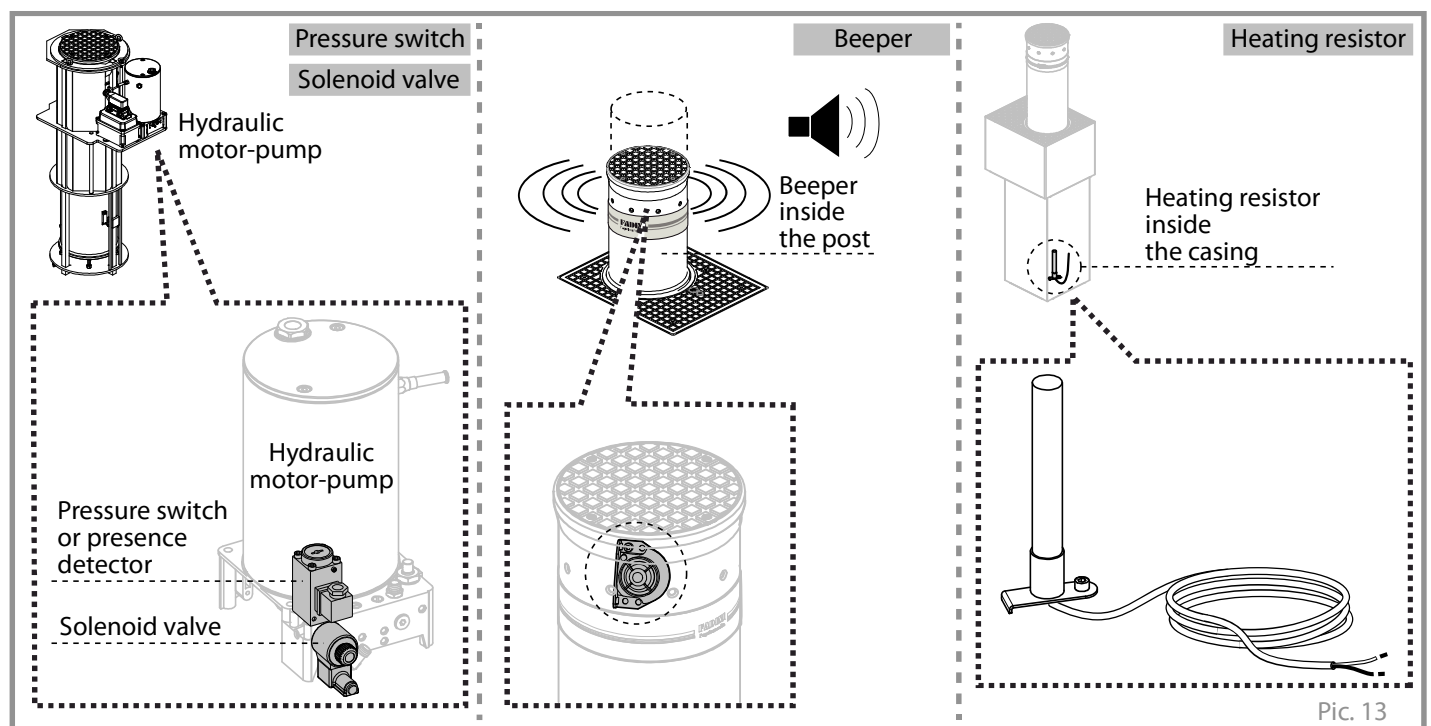

The bollard comes pre-wired (electric motor, limit switches, LEDs and possible optional items such as: beeper, solenoid valve and pressure switch). Connections are in a dedicated watertight box.

Remove the connector from the junction box and bring the connections to the respective terminals by means of a multicore cable (not supplied with the equipment).

English

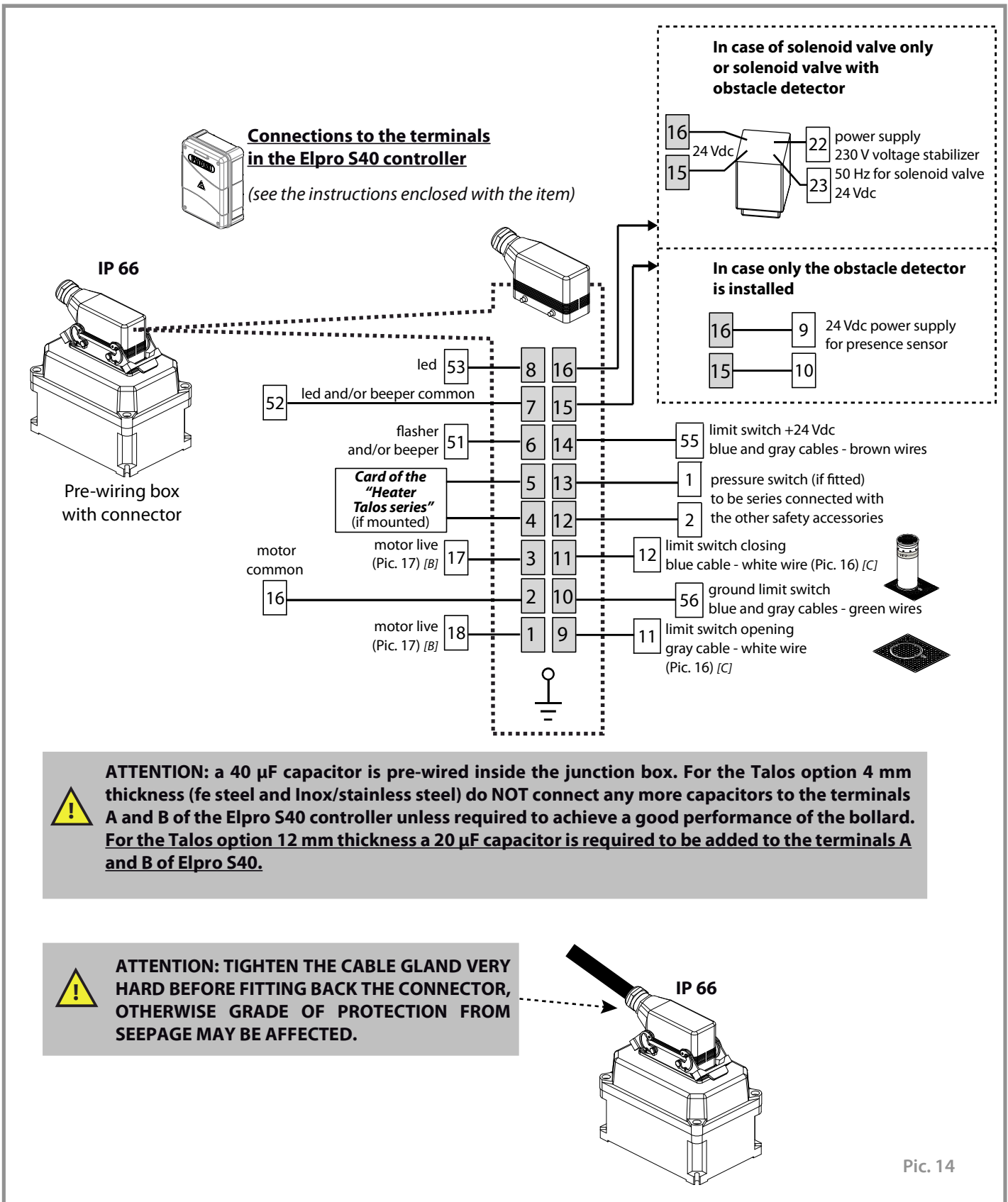

Pic. 14

FIRST RUNNING TEST



ATTENTION: supply the system with power only when wiring is completed.

Once the bollard and all of the the safety (make sure that all the NC contacts in the Elpro S40 controller are actually closed) and command accessories are finally installed, the respective connections to Elpro S40 done and the risk analysis completed, the first running test can be carried out.

If a remote control is available, once satisfied it has been properly match encoded with the radio receiver following the instructions provided with it, pulse once for the post to rise.

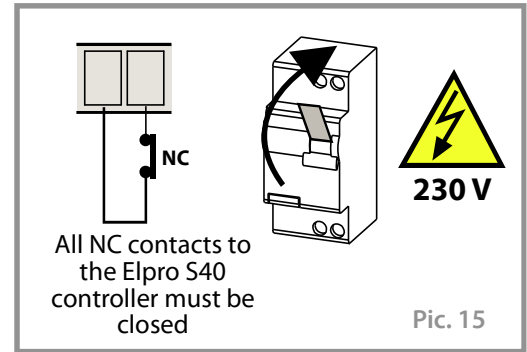

[C] **Check the electrical connections to the limit switches; then, once the electric power is supplied, check the status of the LEDs first of all as follows: with the post in down position the L8 LED must be OFF, while L9 must be ON; if not, swap the connections to terminals 11 and 12 in Elpro S40.**

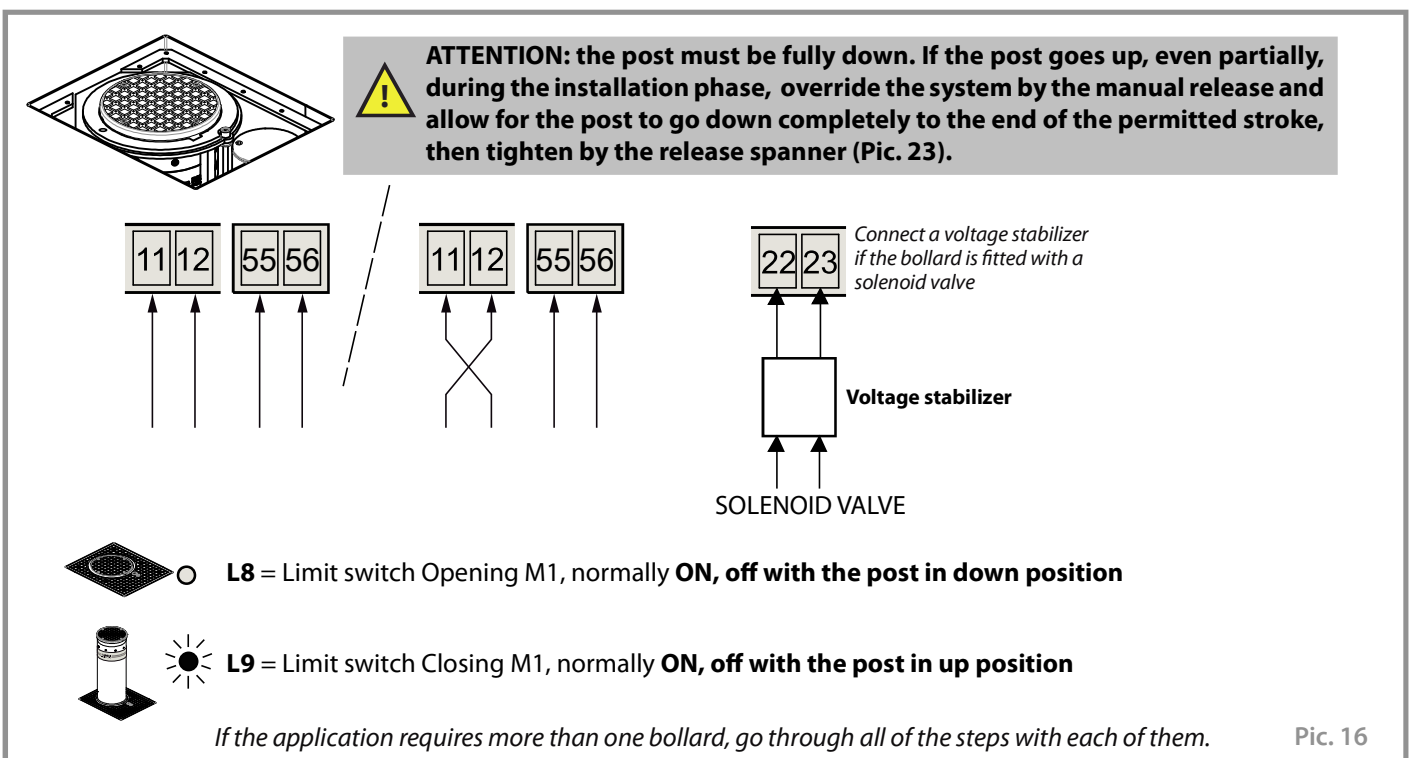

English

[B] Once satisfied that voltage is properly supplied to the system, and provided that the LEDs of the limit switches are correctly switched (post down L8 is OFF), by the first pulse the post should rise, if not swap the motor live connections (in Elpro S40) after voltage supply to the system has been switched off.



ATTENTION: a 40 μF capacitor is pre-wired inside the junction box. For the Talos option 4 mm thickness (steel and inox/stainless steel) do NOT connect any more capacitors to the terminals A and B of the Elpro S40 controller unless required to achieve a good performance of the bollard. For the Talos option 12 mm thickness a 20 μF capacitor is required to be added to the terminals A and B of Elpro S40.

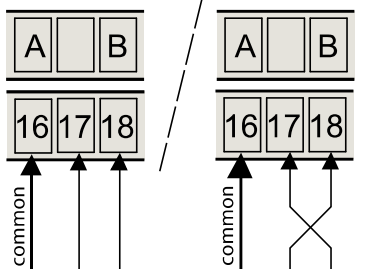

connections to the electric motor of the hydraulic motor pump



1° pulse

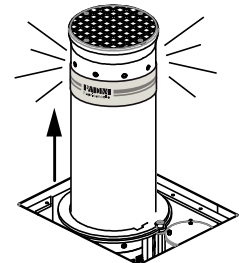

Bollard raised:
gateway closed

If the application requires more than one bollard, go through all of the steps with each

Pic. 17

FIXING THE COVER PLATES OF THE BOLLARD

The cover plate is to firmly rest all over the surface and closely adhere to the circular flange around the post



NOTE WELL: BOLLARD AND COVER PLATE ARE TO BE PERFECTLY CENTERED, SO THAT THE GAP BETWEEN BOLLARD AND COVER PLATE HOLE IS EQUALLY SPACED ALL AROUND

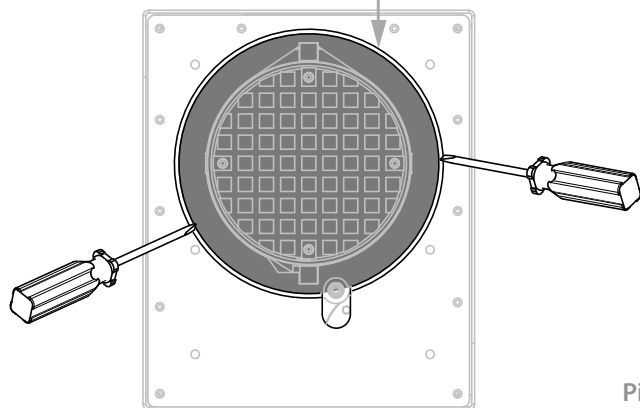
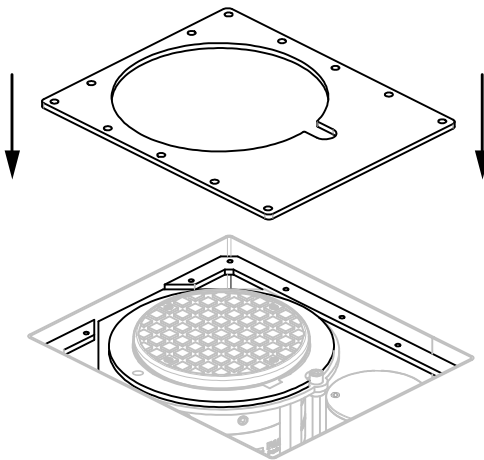

Pic. 18

M10

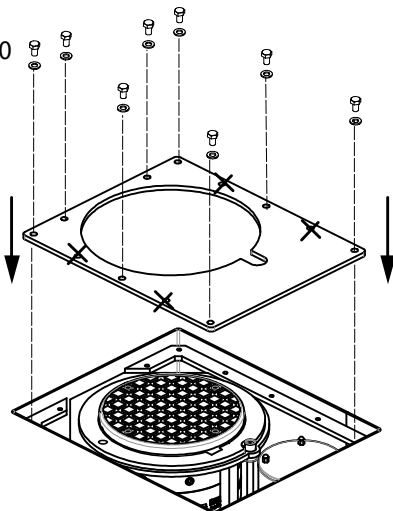

NOTE WELL: IT IS RECOMMENDED THAT ALL OF THE FIXING SCREWS BE GREASED

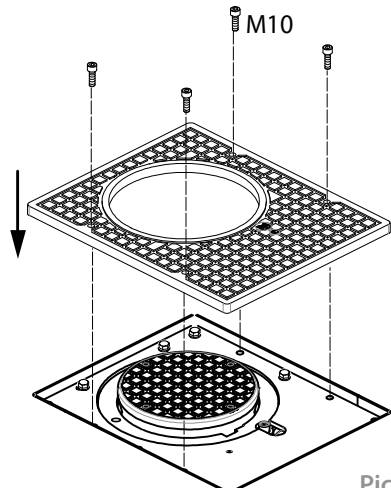

Pic. 19

BOLLARD WITH SOLENOID VALVE (OPTIONAL ACCESSORY)

With the version of the bollard where a solenoid valve (24 Vdc) is fitted, in case of power failure, the post is allowed to lower by itself flat to ground level.

If a solenoid valve is fitted, a voltage stabilizer is also required: this accessory is absolutely necessary and is to be fitted between the solenoid valve power output (terminals 22 and 23) and the solenoid valve.

Be reminded that only one stabilizer can be fitted to each solenoid valve.

ATTENTION: WITH POST THICKNESS 4 mm, BOTH FE STEEL AND INOX/STAINLESS STEEL, IT IS REQUIRED THAT THE POST BE ASSISTED TO REACH THE FULLY FLAT DOWN POSITION.

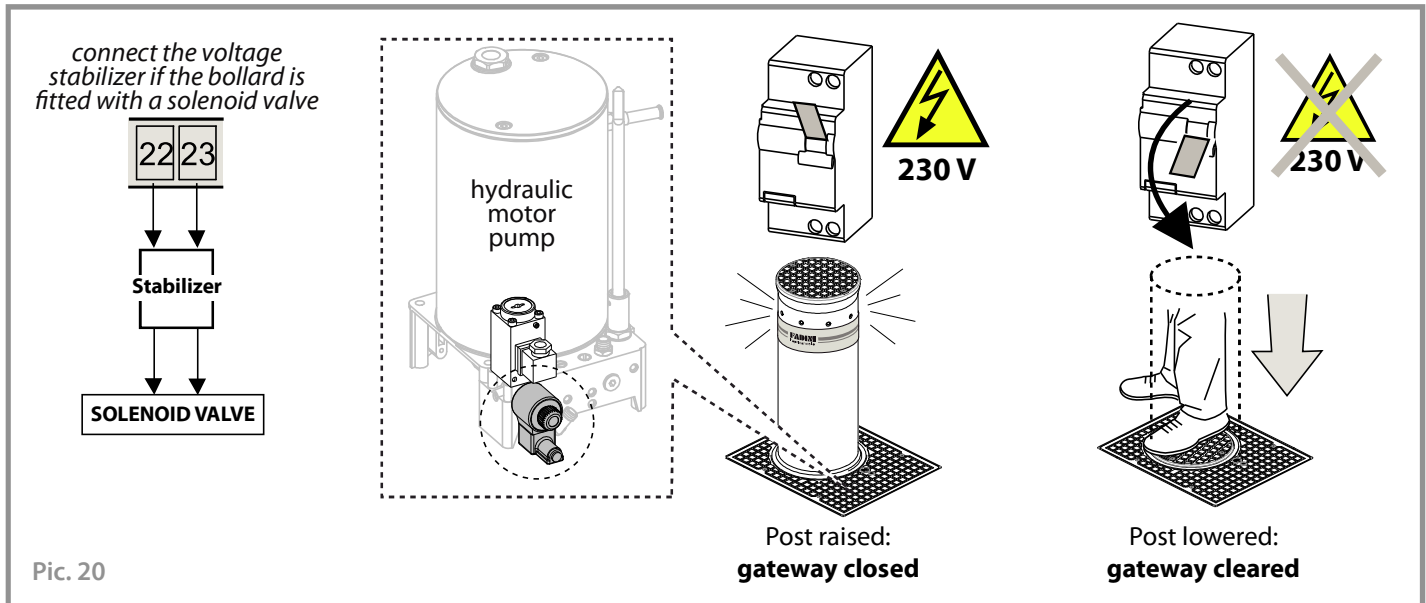

BOLLARD FITTED WITH PRESSURE SWITCH ie. PRESENCE DETECTOR (OPTIONAL ITEM)

In the version where the bollard is fitted with a pressure switch, any obstacle standing on the post prevents it from rising, or should the post be in the rising phase it reverses movement and lowers completely flat to ground level. The pressure switch is factory preset for a minimum weight of about 15 kg. A new setting is possible to be made though, in compliance with the installation requirements.

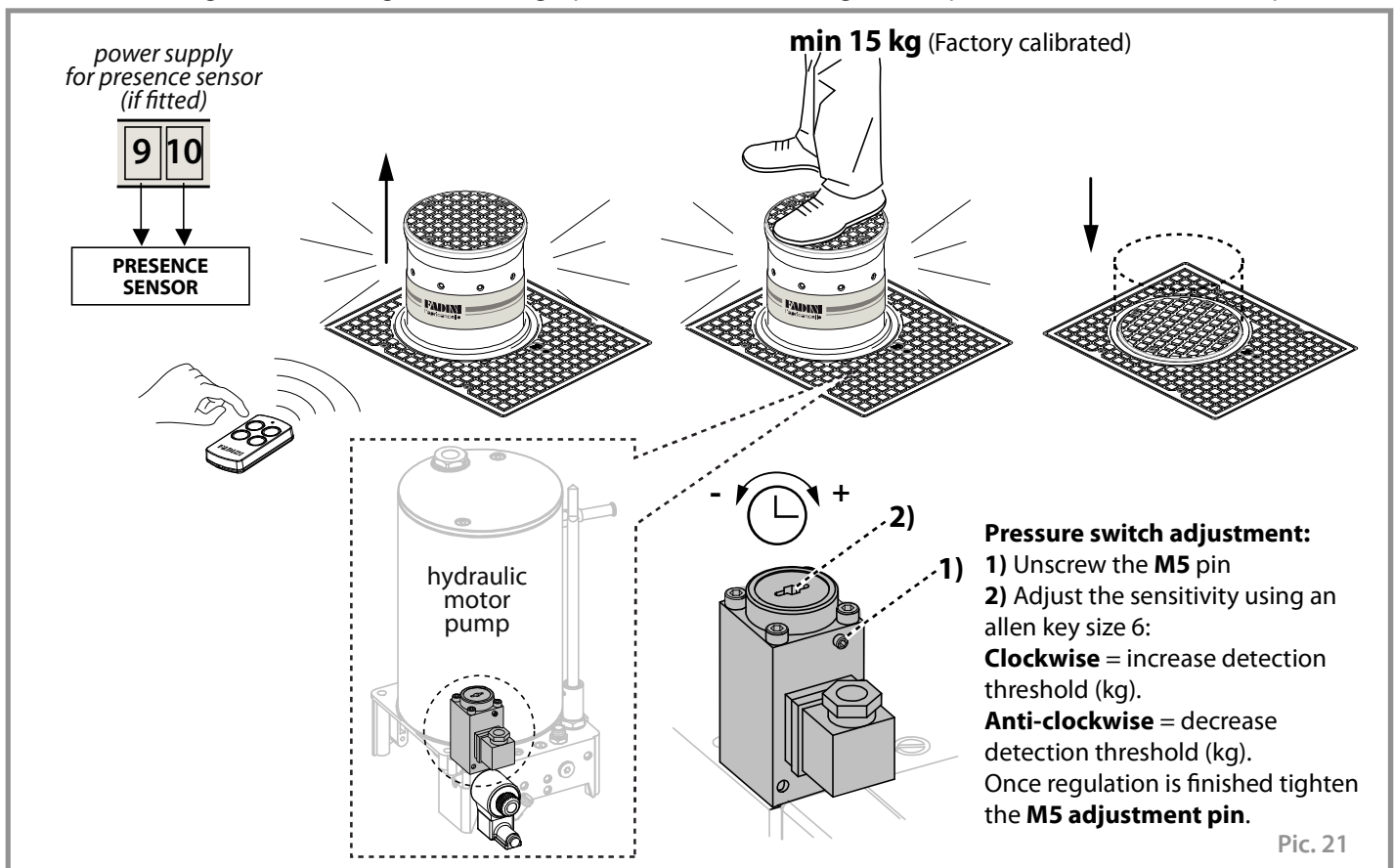

MANUAL RELEASE AND LOWERING OPERATIONS

The bollard has an override system allowing for the manual lowering of the post. A spanner with a universal triangle socket at the end is supplied with the equipment to release the unit and allow manual lowering.

ATTENTION: once the post has been manually lowered, rising can be made possible only by powering the system and pulsing it to rise.

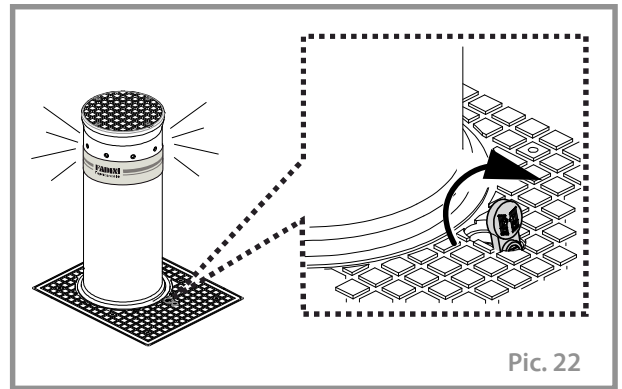

Pic. 22

English

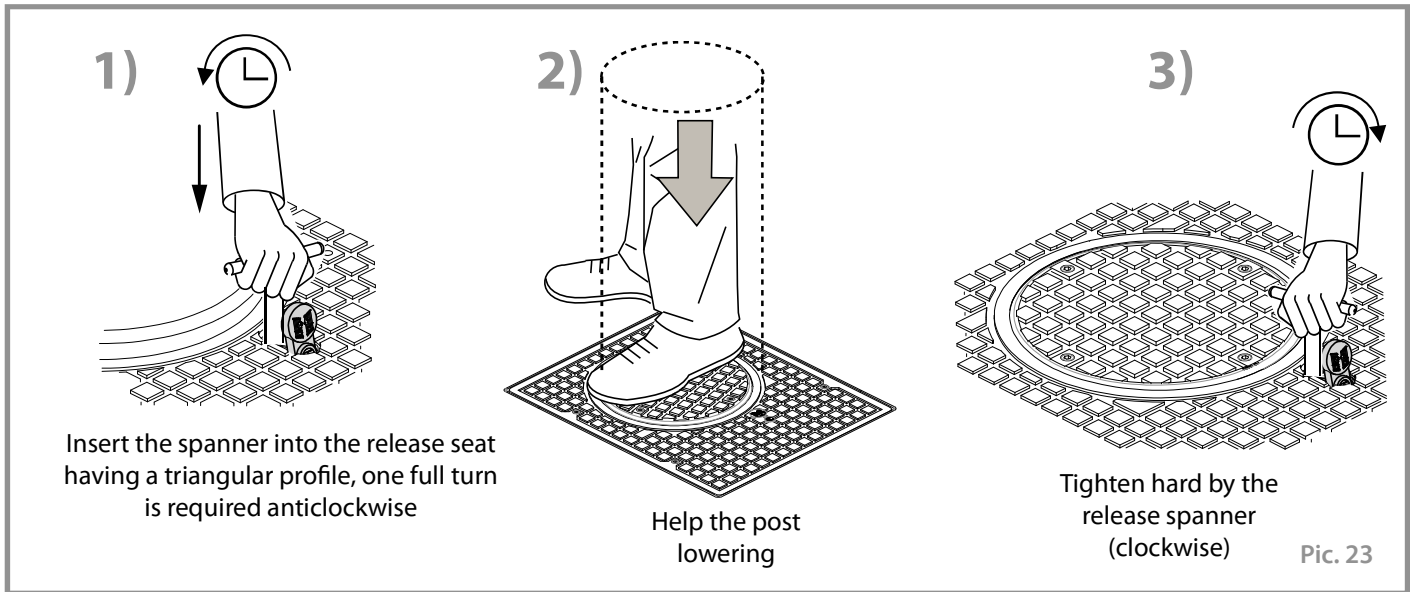

Insert the spanner into the release seat having a triangular profile, one full turn is required anticlockwise

Help the post lowering

Tighten hard by the release spanner (clockwise)

Pic. 23

English

MAINTENANCE RECORD
hand over to the end user of the installation

Installation address:	Maintainer:	Date:
-----------------------	-------------	-------

<p>Installation type:</p> <p>Sliding gate <input type="checkbox"/> Folding door <input type="checkbox"/></p> <p>Swinging gate <input type="checkbox"/> Road barrier <input type="checkbox"/></p> <p>Over-head door <input type="checkbox"/> Bollard <input checked="" type="checkbox"/></p> <p>Lateral folding door <input type="checkbox"/> <input type="checkbox"/></p>	<p>Operator model:</p> <p>Dimensions per gate leaf:</p> <p>Weight per gate leaf:</p>	<p>Quantity of models installed:</p> <p>Installation date:</p>
--	--	--

NOTE WELL: this document must record any ordinary and extraordinary services including installation, maintenance, repairs and replacements to be made only by using Fadini original spare parts. This document, for the data included in it, must be made available to authorized inspectors/officers, and a copy of it must be handed over the end user/s.

The installer/maintainer are liable for the functionalities and safety features of the installation only if maintenance is carried on by qualified technical people appointed by themselves and agreed upon with the end user/s.

N°	Service date	Service description	Technical maintainer	End user/s
1				
2				
3				
4				
5				
6				

<p>_____</p> <p>Stamp and signature installation technician/maintainer</p>	<p>_____</p> <p>Signed for acceptance end user buyer</p>
--	--

give to the end-user of the installation



OPERATIONS FOR ORDINARY ROUTINE MAINTENANCE OF FADINI AUTOMATIC BOLLARDS (EVERY SIX MONTHS)

The standard maintenance routine sequence is as follows:

- Clean the ground cylinder and suck all material settlements.
- Clean water drains located at the bottom of the ground cylinder and/or excavation pit.
- Check any possible oil leaking from the hydraulic piston and, in case, fix it.
- Overhaul the screws fastening the bollard to the ground cylinder, making sure they are properly tightened and lubricated.
- Check the oil-hydraulic motor-pump and oil pressure by assessing the rising times of the bollard. If required, top up oil in the reservoir and/or parallel add an extra capacitor to the existing one (instructions manual is to be referred to).
- Check the correct functioning of the signal LED lights (if incorporated) in the bollard head.
- Sight check the electronic board controlling the bollard/s (e.g.: "flooded" relay contacts, oxidized terminal clamps, etc.).
- Check the correct functioning and positioning of the limit switches.
- Check the release system for bollard manual operations.
- Clean and recondition the rising cylinder if required, e.g.: paint patching up, replacing the back reflecting sticker and /or the cover fitted with rubber edge.

IF OPTIONAL ACCESSORIES ARE INCLUDED, FURTHER MAINTENANCE IS REQUIRED AS FOLLOWS:

- Check the correct functioning of the safety accessories such as the inductive loop/s and the photocells.
- Check the correct functioning of the radio receiver and all of the remote controls.
- Check the correct functioning of the pressure switch.
- Check the correct functioning of the beeper.
- Check the correct functioning of the traffic lights and the respective control card.
- Check the correct functioning of the solenoid valve in emergency cases such as power failure or disconnection, assess therefore the status of the 24 Vdc voltage stabilizer.
- Check the correct functioning of EAR 35 acoustic analyzer to lower the bollard in emergency.



This symbol indicates that a particular attention is required on the installation phases and on running the operator. Failure to observe these indications may cause incorrect functioning of the bollard.



INFORMATION ABOUT SAFETY AND PROPER FUNCTIONING OF THE SYSTEM



- 1) Installation operations, testing, analysis of the risks and future maintenance are to be executed by qualified and authorized technicians in compliance with the existing regulations (www.fadini.net/supporto/download)
- 2) This automatic system is intended to be exclusively used for the applications described in this manual, including all of the safety and command accessories, at least as required.
- 3) Any application not indicated in this manual may cause malfunctioning or damages to people and properties.
- 4) Make sure the soil is adequate to take the bollard to avoid that settling at a later stage causes problems to the system
- 5) Make sure the site is free from utilities that may interfere with it.
- 6) Make sure that electromagnetic sources are at a suitable distance from the accessories, especially from the loop detectors. The magnetic fields of other sources might affect the detections of the safety loops as well as those of the other command and safety devices of the system.
- 7) Make sure the power supply to the electric motor is 230 V (50 Hz).
- 8) **It is recommended either of the following power supply cables:**
 - **cable type BUT FLESSIBILE FG 7OR 12x1,5 mm² (up to 50 m maximum): for the TALOS bollard in the standard version, without optional accessories;**
 - **cable type BUT FLESSIBILE FG 7OR 12x1,5 mm² (up to 50 m maximum): for the TALOS bollard in the version fitted with one optional accessory maximum (either solenoid valve, obstacle detector or heater);**
 - **cable type BUT FLESSIBILE FG 7OR 16x1,5 mm² (up to 50 m maximum): for the TALOS bollard in the version fitted with two or all of the three optional accessories (solenoid valve, obstacle detector and heater);**
- N.W. The presence or not of the beeper on the TALOS bollard, does not affect the cable choice.**
- The section of the ground cable is to be chosen in compliance with the requirements of the installation site.**
- 9) In case any components or accessories need replacing, use only original parts as provided by the manufacturer.
- 10) The installer shall provide the final user with information related to all of the operating commands and functions of the system, including that concerning lowering of the post in case of an emergency (manual release operation).
- 11) The installer shall inform the final user of the dangers coming from the presence of persons, especially children, in the proximity of the bollard.
- 12) The manufacturer reserves the right to change this manual without previous notice.

As far as configuration and execution of the system are concerned, these are to comply with the laws in the country of installation.



Meccanica Fadini is not liable for any possible damages derived from incorrect use or from any use not indicated in this manual, furthermore it is not answerable for malfunctioning caused by the use of materials or accessories not approved by the company itself.

It is to be noted that the product respects the impact and breakout resistance values as indicated provided that the installation of the same is carried out in observance of the specifications included in this manual of instructions. Various factors are to be carefully taken into consideration such as compaction index, soil permeability coefficient, concrete type, which may affect the indicated values even significantly.

PRODUCT SPECIFICATIONS

Fully retractable automatic bollard for heavy duty applications, made up of an incorporated oil-hydraulic motor pump unit and an oil-hydraulic actuator inside the moving cylinder. Suitable for protecting garages, shops, gateways to shopping centers, banks, car saloons and generally speaking all those areas under risk of attack requiring safeguard. For residential, community and industrial installations. IP 67. The height of the rising cylinder (out of the ground) can be 500/600/700/800 mm. Rising cylinder made of S235JRH steel, thickness 4 mm and Ø 275 mm or S355J2H steel, thickness 12 mm, cathaphoresis treated and powder coated. Rising cylinder also available in 4 mm AISI 304 or AISI 316 brushed stainless steel. Rubber ring on rising cylinder head. Cathaphoresis treated aluminium cover, finished to provide a slip-proof treading surface. Rising cylinder fitted with high intensity, microprismatic, retroreflecting approved sticker (h 80 mm), and 9 signalling LEDs all around the top with flashing light. Hot dip galvanized steel casing for ground foundation, fitted with a cover plate allowing access to the hydraulic release for manual lowering of the bollard in an emergency by a special spanner having a triangular socket. With rising cylinder thickness 4 mm: impact resistance 52.000 J, breakout resistance 320.000 J. HRC (High Resistance Cylinder) option: impact resistance 70.000 J, breakout resistance 420.000 J. With rising cylinder thickness 12 mm: impact resistance 60.000 J, breakout resistance 450.000 J. HRC (High Resistance Cylinder) option: impact resistance 90.000 J, breakout resistance 550.000 J. Static load max 1.500 kg in standing position, max 20.000 kg in lowered position. Working temperature -40 °C +80 °C. Supply voltage 230 Vac ± 10%, 50 Hz. Absorbed power 1.100 W. Connector and junction box IP 66 for cabling. Rising time, rising cylinder thickness 4 mm: ~ 2,14 s [height H 500 mm]; ~ 2,57 s [height H 600 mm]; ~ 3,0 s [height H 700 mm]; ~ 3,42 s [height H 800 mm]. Rising time, rising cylinder thickness 12 mm: ~ 2,80 s [height H 500 mm]; ~ 3,40 s [height H 600 mm]; ~ 4,0 s [height H 700 mm]; ~ 4,50 s [height H 800 mm]. Frequency of use 2.000 cycles/day. Hydraulic device to lock the bollard in standing position, solenoid valve on request for the spontaneous descent of the bollard in case of power failure.

English

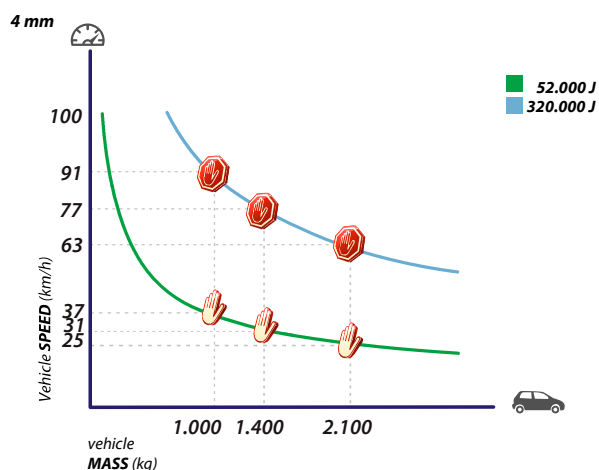

Various factors, such as the compaction index, soil permeability coefficient and kind of concrete may reduce the values indicated in the diagram even significantly.

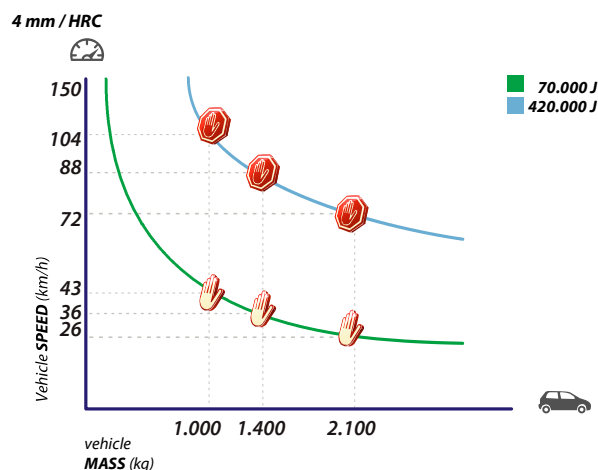

Various factors, such as the compaction index, soil permeability coefficient and kind of concrete may reduce the values indicated in the diagram even significantly.

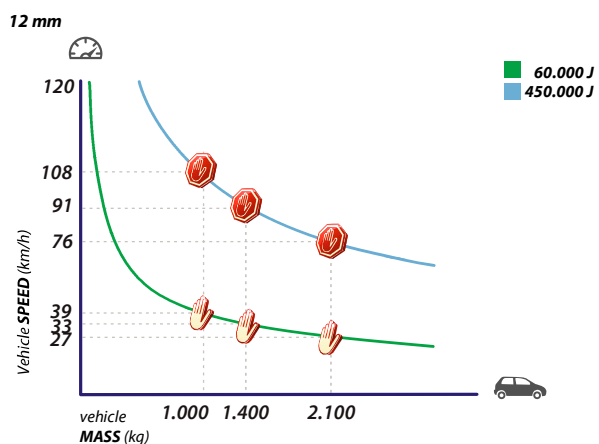

Various factors, such as the compaction index, soil permeability coefficient and kind of concrete may reduce the values indicated in the diagram even significantly.

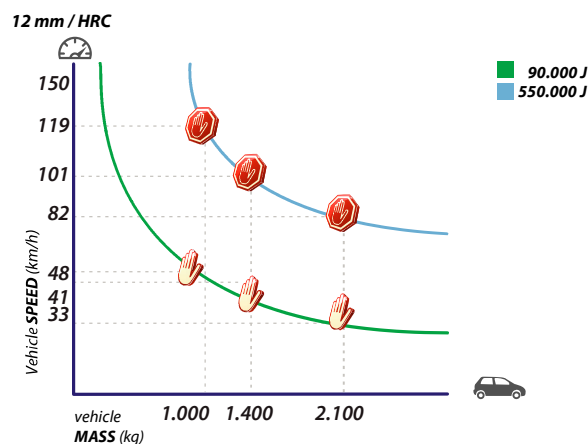

Various factors, such as the compaction index, soil permeability coefficient and kind of concrete may reduce the values indicated in the diagram even significantly.

TECHNICAL DATA

BOLLARD

Post diameter	Ø 275 mm
Post thickness	4 and 12 mm
Post height range	500, 600, 700 and 800 mm
Finishing of the Fe post	polyester powder coating RAL 1028 (4 mm) - RAL 7016 (12 mm)
Piston diameter	30 mm
Shaft diameter	16 mm
Piston stroke range	510, 610, 710 and 810 mm
Factory set thrust power	61 daN (61 kg)
Frequency of use	intensive (2.000 cycles/day)
LED / beeper power adaptor	in: 230 V - 50 Hz out: 12 Vdc 600 mA
LED lights	12 Vdc
Post material	S235JRH (4 mm) steel S355J2H (12 mm) steel AISI 304 inox / AISI 316 inox brushed SS steel

	standard	HRC
Impact resistance (thick. 4)	52.000 J	70.000 J
Crash resistance (thick. 4)	320.000 J	420.000 J
Impact resistance (thick. 12)	60.000 J	90.000 J
Crash resistance (thick. 12)	450.000 J	550.000 J
Maximum static load	20.000 kg	20.000 kg

ELECTRIC MOTOR

Absorbed power	1.100 W
Power supply	230 V
Frequency	50 Hz
Rated current	1,8 ÷ 3,5 A
Maximum current	6 A
Intermittent service	S3
Capacitor	40 µF
Motor rotation speed	2.800 rpm

HYDRAULIC MOTOR PUMP TUNIT 3.20LP

Pump type	P20
Working pressure	1 MPa (10 bar)
Working temperature	- 20 °C + 80 °C
Oil type	Oil Fadini - code 708L
Oil reservoir	3 liters
Protection grade	IP 67 without pressure switch and solenoid valve IP 65 with pressure switch and solenoid valve

Individual weight of the bollards [D]

Model	stroke (mm)	post thickness (mm)	weight [E] (kg)	time (s)		Model	stroke (mm)	post thickness (mm)	weight [E] (kg)	time (s)	
				rising	lowering					rising	lowering
TALOS 9450	500	4	196	2,14	2,00	TALOS 9651	500	12	234	2,80	2,14
TALOS 9450/HRC	500	4	202	2,14	2,00	TALOS 9651/HRC	500	12	252	2,80	2,14
TALOS 9460	600	4	226	2,57	2,40	TALOS 9661	600	12	258	3,40	2,57
TALOS 9460/HRC	600	4	234	2,57	2,40	TALOS 9661/HRC	600	12	266	3,40	2,57
TALOS 9470	700	4	232	3,00	2,80	TALOS 9671	700	12	263	4,00	3,00
TALOS 9470/HRC	700	4	240	3,00	2,80	TALOS 9671/HRC	700	12	275	4,00	3,00
TALOS 9480	800	4	240	3,42	3,20	TALOS 9681	800	12	288	4,50	3,42
TALOS 9480/HRC	800	4	246	3,42	3,20	TALOS 9681/HRC	800	12	291	4,50	3,42

[D] With Talos models fitted with a solenoid valve and moving cylinder thickness 4 mm, the weights are 15 kg higher than those indicated in the table.

[E] Weight of automatic bollard complete with casing.

